

# **Nokia Customer Care**

## **7 - RF Description and Troubleshooting**

[This page intentionally blank]

**Table of Contents**

	<b>Page No</b>
<b>CMT RF</b> .....	<b>5</b>
Top-level description.....	5
RA-8 test point locations.....	6
Test points.....	7
RF implementation in RA-8.....	11
Frequency plan.....	11
RF block diagram.....	12
Antenna switch module (ASM).....	13
DC characteristics.....	13
RF characteristics.....	16
Channel numbers and frequencies.....	16
<b>RF Troubleshooting</b> .....	<b>17</b>
Receiver description and troubleshooting.....	17
Rx front end.....	17
Antenna.....	17
Receiver characteristics.....	18
General instructions for Rx troubleshooting.....	19
Transmitter description and troubleshooting.....	26
Power amplifier.....	26
RF ASIC Honi.....	26
AFC function.....	27
Transmitter characteristics.....	27
General instructions for Tx troubleshooting.....	27
Additional information for EDGE troubleshooting.....	34
Pictures of EDGE transmitter signals.....	38
Synthesizer description and troubleshooting.....	42
Frequency synthesizers.....	42
General instructions for synthesizer troubleshooting.....	42
Frequency Lists.....	47
RF tunings after repairs.....	50

[This page intentionally blank]

## CMT RF

---

### ■ Top-level description

The RF module performs the necessary high frequency operations of the EGSM900/1800/1900 tripleband (EDGE) engine. Both the transmitter and receiver have been implemented by using direct conversion architecture which means that the modulator and demodulator operate at the channel frequency.

The core of the RF is an application-specific integrated circuit, Honi. Another core component is a power amplifier module which includes two amplifier chains, one for EGSM900 and the other for GSM1800/GSM1900.

Other key components include

- 26 MHz VCTCXO for frequency reference
- 3296-3980 MHz SHF VCO (super high frequency voltage controlled oscillator)
- Antenna switch module (ASM)
- Three SAW filters
- BAW-LNA module

The control information for the RF is coming from the baseband section of the engine through a serial bus, referred later on as RFBUS.

The whole RF circuitry is located on one side of the 8-layer PWB.

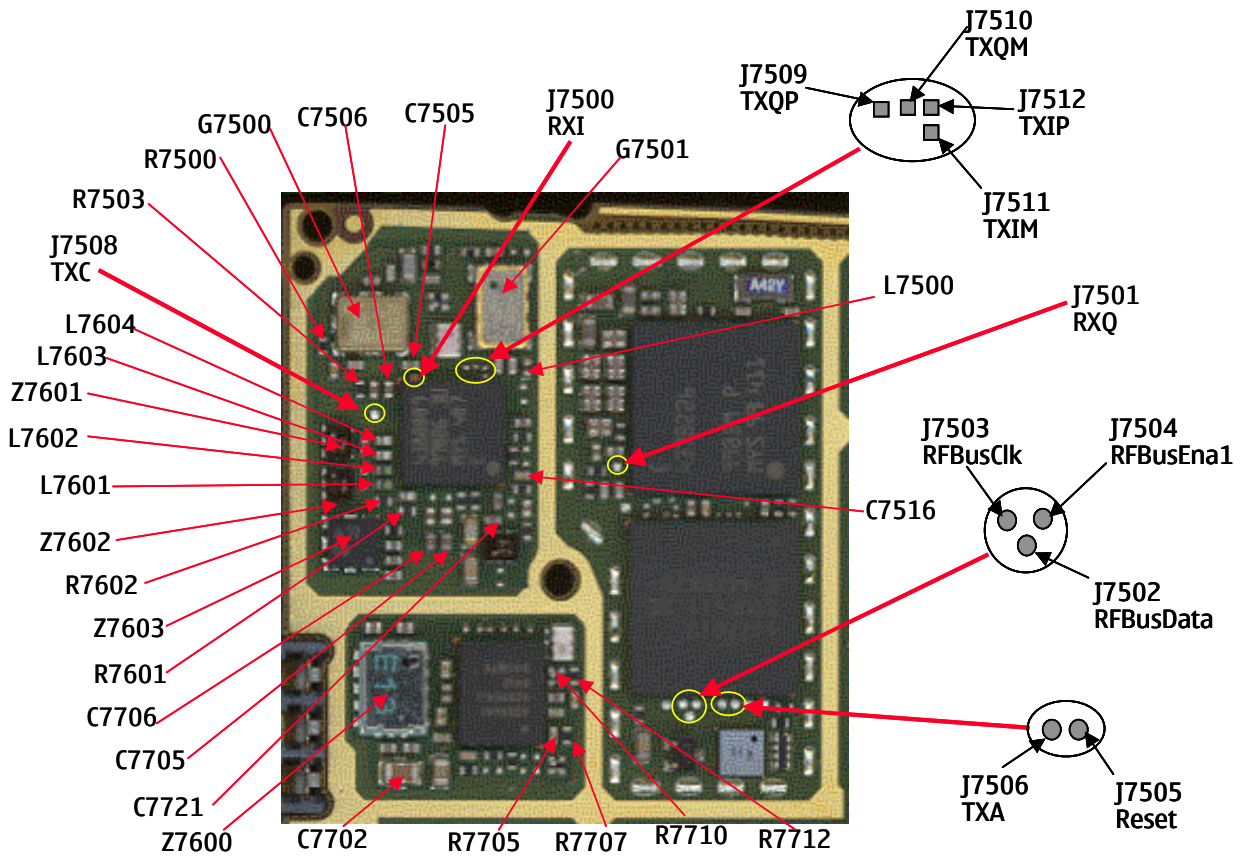
EMC leakage is prevented by using a metal shield with gasket. The RF circuits are separated into two blocks.

- PA, ASM, TK balun
- Honi RF IC, VCO + balun, VCTCXO, BAW-LNA, Rx filter, Tx filter

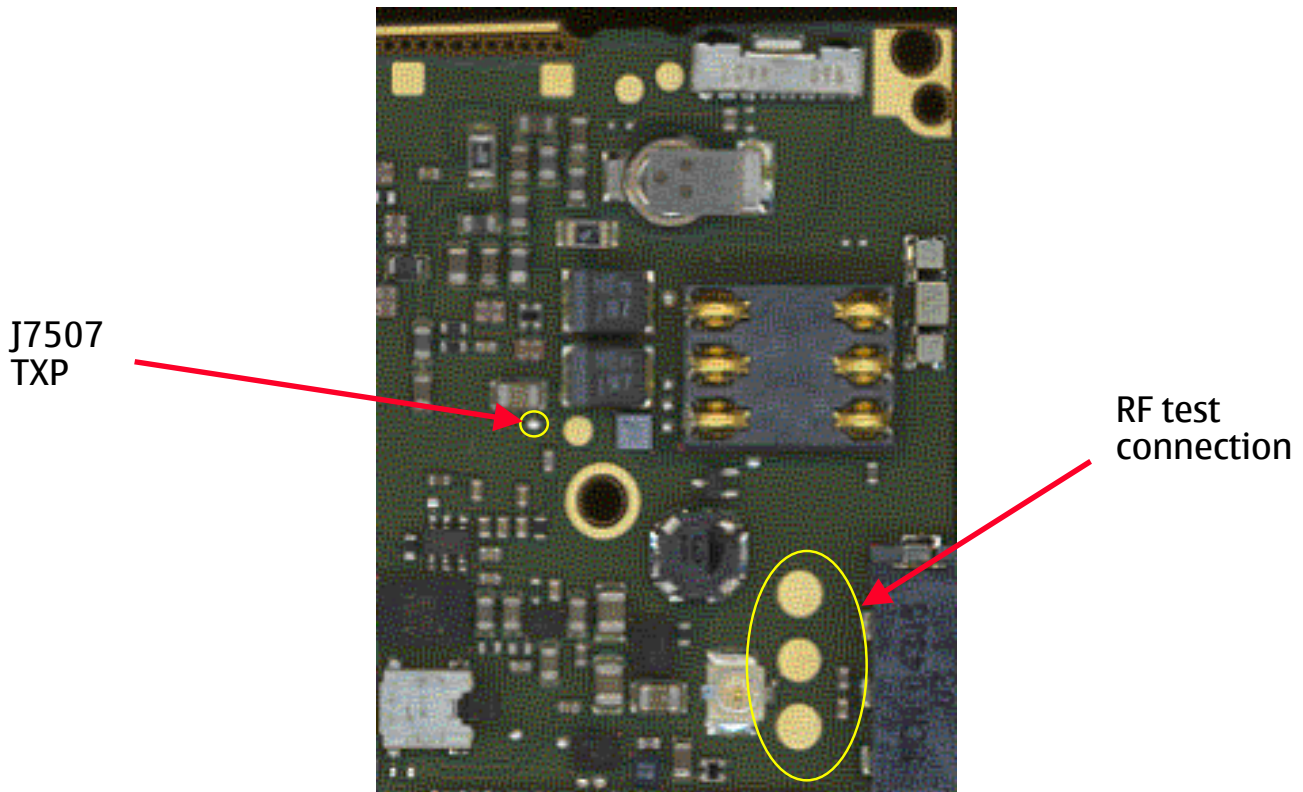
The RF transmission lines constitute of striplines and microstriplines after PA.

■ RA-8 test point locations

Figure 1: Top view



**Figure 2: Bottom view**



■ **Test points**

**Table 1: Rx test points**

Signal name:	Ref:
LNAB_P	Z7603
LNA_P	Z7603
RXI	J7500
RXQ	J7501

**Table 2: Antenna switch test points**

Signal name:	Ref:
VANT_1	Z7600
VANT_2	Z7600
VANT_3	Z7600
GSM_Rx	Z7600
DCS_Rx	Z7600
PCS_Rx	Z7600
TX_IN_EGSM	Z7600

**Table 3: Honi serial interface test points**

Signal name:	Ref:
RFBusClk	J7503
RFBusEna1	J7504
RFBusData	J7502
Reset	J7505

**Table 4: Synthesizer test points**

Signal name:	Ref:
VCO_out	G7500
VCTCXO_out	G7501

**Table 5: GSM900 Rx Honi input test points**

	Ref:
RX filter	Z7601
Inductor	L7603
Inductor	L7604



**Table 6: GSM1800 Rx Honi input test points**

	Ref:
Filter	Z7602
Inductor	L7601
Inductor	L7602

**Table 7: GSM1900 Rx Honi input test points**

	Ref:
BAW-LNA	Z7603 pin 7
Resistor	R7601
Resistor	R7602

**Table 8: Tx PA input test points**

Signal name:	Ref:
Rfin_900	R7705
Rfin_1800/190	R7710

**Table 9: Tx filter/balun input test points**

Signal name:	Ref:
RfinP_900	C7721
RfinM_900	C7721
RfinP_1800_1900	C7705
RfinM_1800_1900	C7706

**Table 10: PA control signal test points**

Signal name:	Ref:
VPCTRL_900	R7707
VPCTRL_1800_1900	R7712
TXIM	J7511
TXIP	J7512
TXQM	J7510
TXQP	J7509
TXC	J7508
TXP	J7507 (test pad)
TXA	J7506

**Table 11: Rx test points**

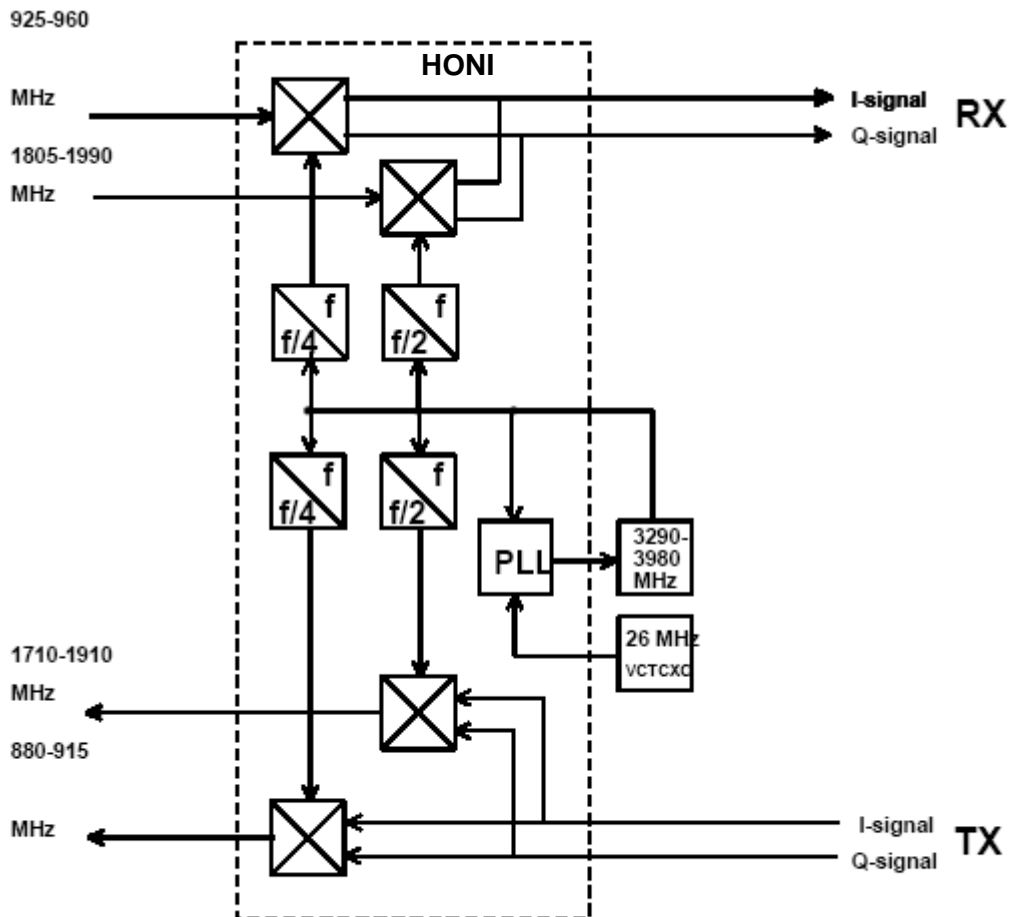
Signal name:	Ref:
VR1	
VR2	C7516
VR3	L7500
VR4	
VR5	C7505
VR6	C7506
VR7	R7500
VrefRF01	R7503
VBAT	C7702

■ RF implementation in RA-8

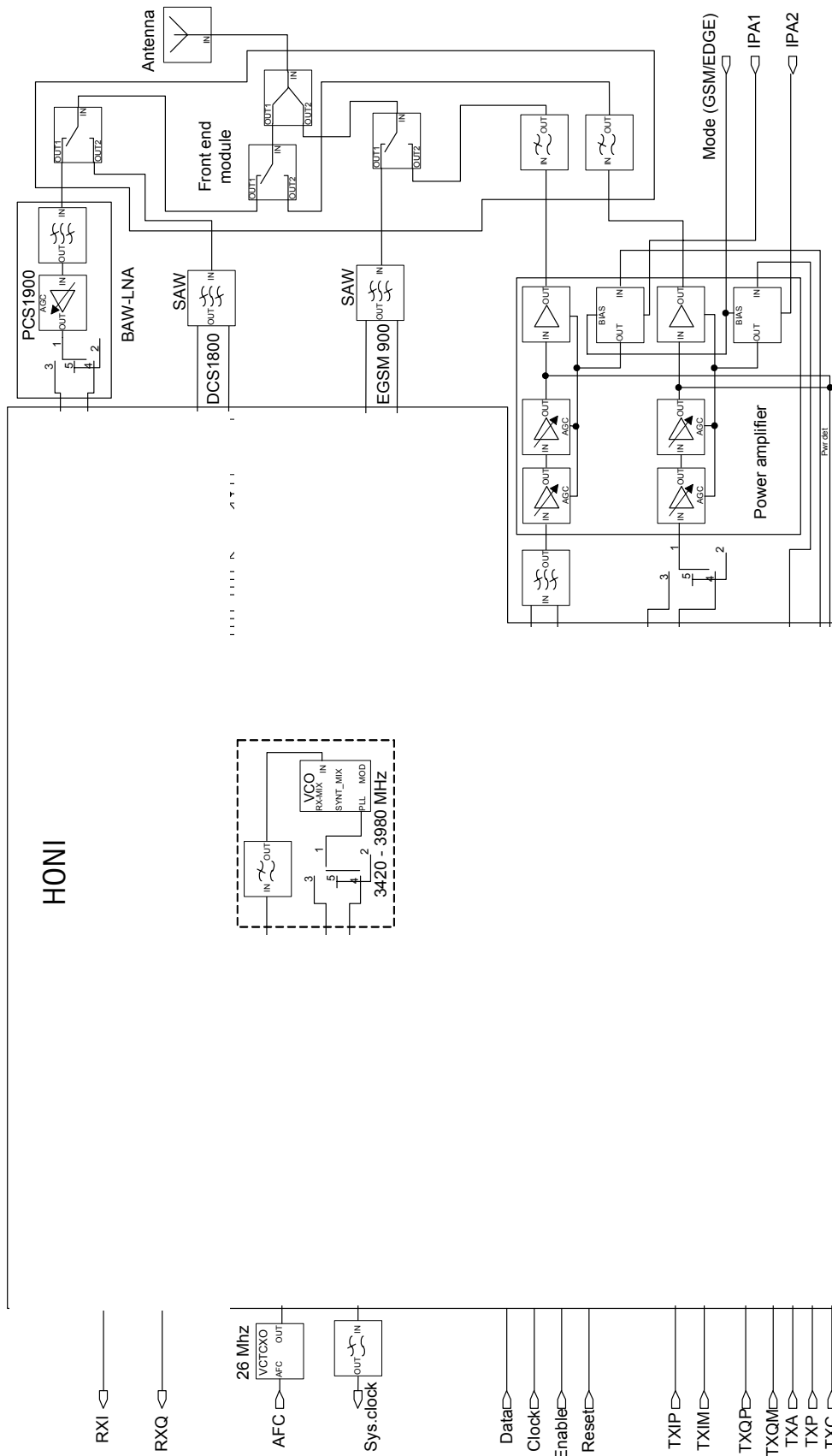
**Frequency plan**

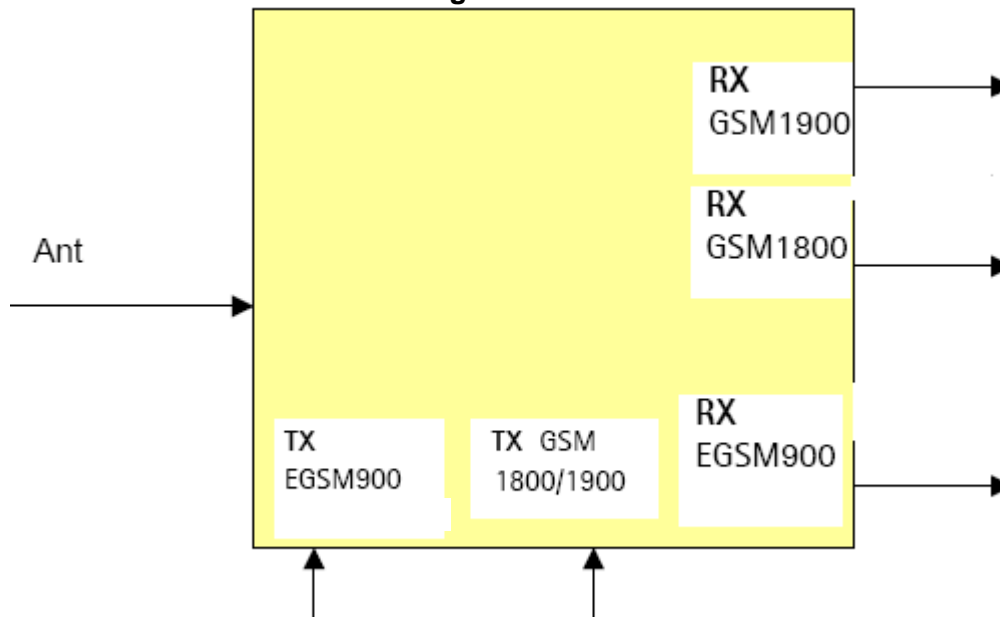
The RF frequency plan is shown below. The VCO operates at the channel frequency multiplied by two or four depending on the frequency band of operation. This means that the baseband modulated signals are directly converted up to the transmission frequency and the received RF signals directly down to the baseband frequency.

**Figure 3: RF frequency plan**



RF block diagram



**Antenna switch module (ASM)****Figure 4: ASM****DC characteristics****Regulators**

The transceiver baseband section has a multi function analog ASIC, UEM, which contains among other functions six pieces of 2.78 V linear regulators and a 4.8 V switching regulator. All the regulators can be controlled individually by the 2.78 V logic directly or through a control register. Normally, direct control is needed because of switching speed requirement: the regulators are used to enable the RF-functions which means that the controls must be fast enough.

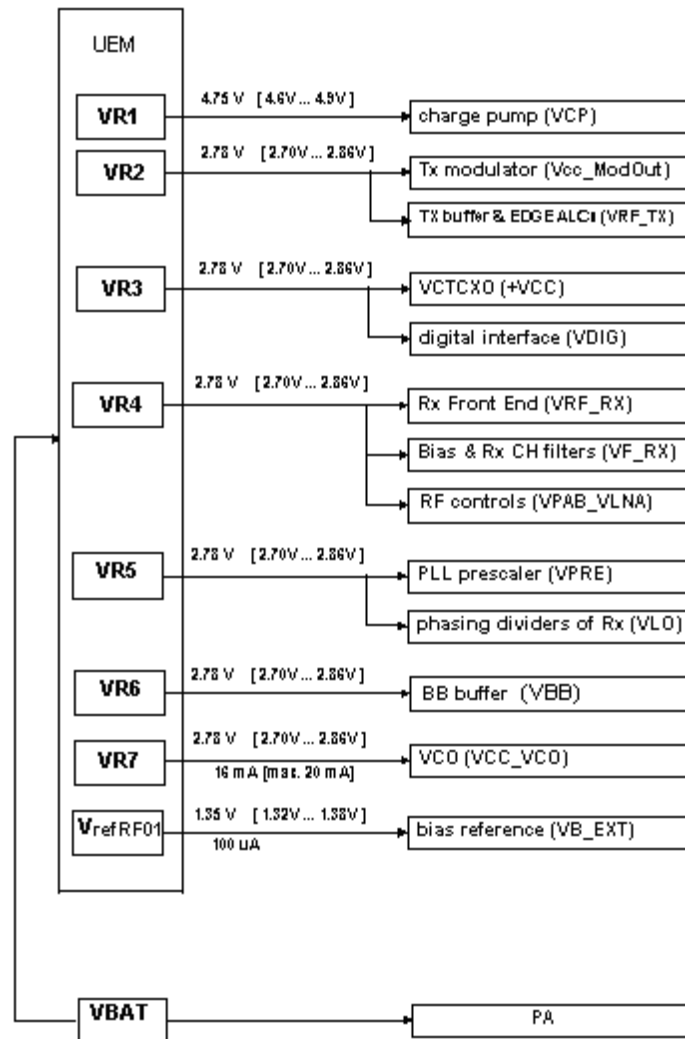
The use of the regulators can be seen in the power distribution diagram which is presented in Figure 6, "Power distribution diagram," on page 15.

The seven regulators are named VR1 to VR7. VrefRF01 is used as a reference voltage for Honi.

The regulators (except for VR7) are connected to the Honi. Different modes of operation can be selected inside the Honi according to the control information coming through the RFBUS.

**DC supply currents**

**Figure 5: DC power supplies**



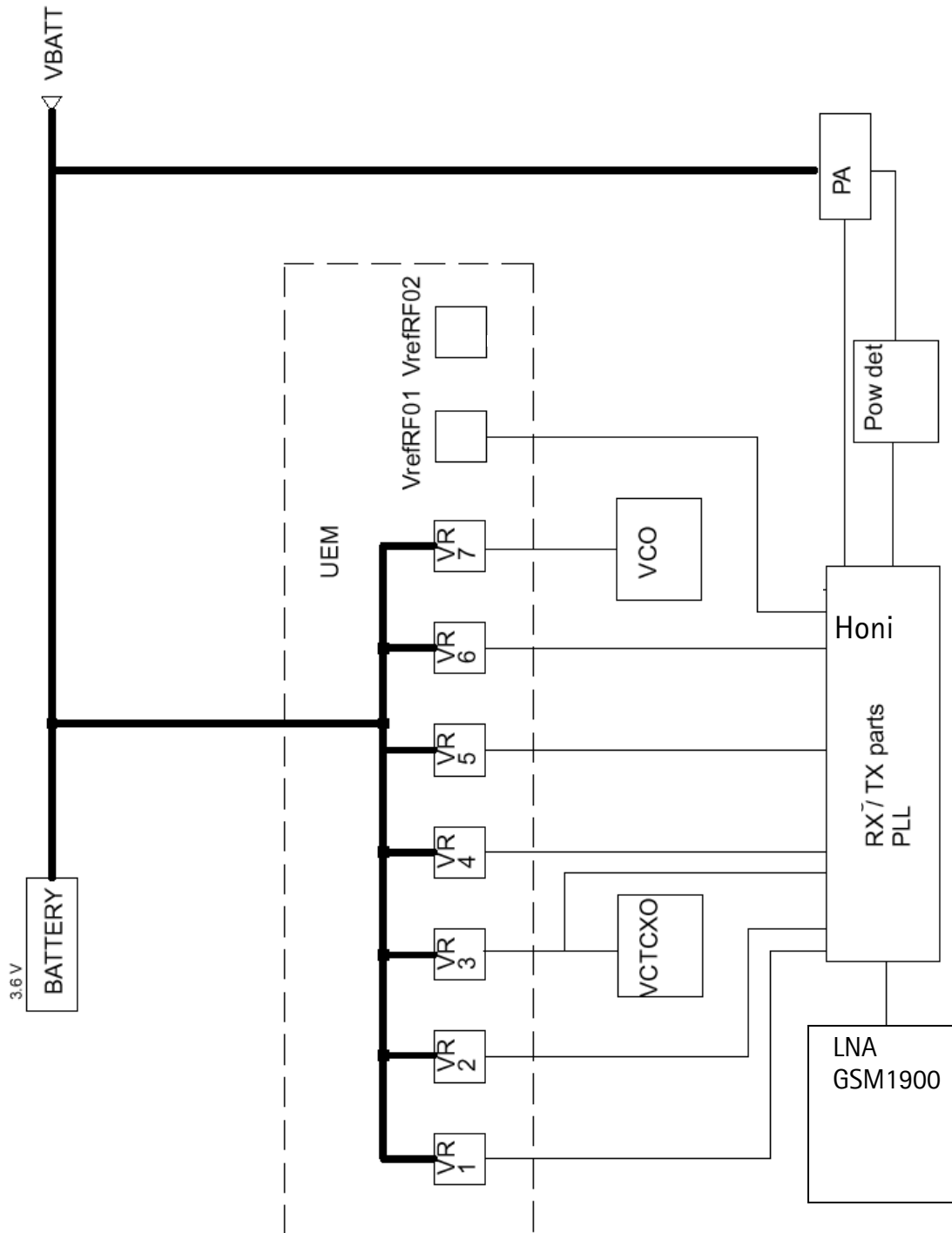
**Typical current consumption**

The table shows the typical current consumption in different operation modes.

Operation mode	Current consumption	Notes
Power OFF	< 10 uA	Leakage current (triple band PA)
Rx, EGSM900	75 mA, peak	
Rx, GSM1800/GSM1900	70 mA, peak	
Tx, power level 5, EGSM900	1700 mA, peak	
Tx, power level 0, GSM1800/GSM1900	1000 mA, peak	

**Power distribution diagram**

**Figure 6: Power distribution diagram**



■ **RF characteristics**

***Channel numbers and frequencies***

System	Channel number	TX frequency	RX frequency	Unit
EGSM	$0 \leq n \leq 124$	$F = 890 + 0.2 * n$	$F = 935 + 0.2 * n$	MHz
	$975 \leq n \leq 1023$	$F = 890 + 0.2 * (n - 1024)$	$F = 935 + 0.2 * (n - 1024)$	MHz
DCS1800	$512 \leq n \leq 885$	$F = 1710.2 + 0.2 * (n - 512)$	$F = 1805.2 + 0.2 * (n - 512)$	MHz
PCS1900	$512 \leq n \leq 810$	$F = 1850.2 + 0.2 * (n - 512)$	$F = 1930.2 + 0.2 * (n - 512)$	MHz



## RF Troubleshooting

---

All measurements should be done using a spectrum analyzer with a high-frequency high-impedance passive probe (LO-/reference frequencies and RF power levels) and an oscilloscope with a 10:1 probe (DC-voltages and low frequency signals).

The RF section is build around one RF ASIC (Honi N7500). For easier troubleshooting, this RF troubleshooting document is divided into sections.

Before changing Honi, please check that both supply voltages and serial communication coming from baseband to Honi are OK. Please note that the grounding of the PA module is directly below the PA module, so it is difficult to check or change.

Most RF semiconductors are static discharge sensitive! Therefore ESD protection must be taken care of during repair (ground straps and ESD soldering irons). Honi and PA are moisture sensitive and thus must be handled as described in the Special Component Handling Document.

Apart from key components described in this document there are a lot of discrete components (resistors, inductors and capacitors) of which troubleshooting is done by checking if the soldering of the component is done properly (for factory repairs checking if it is missing from the PWB). You can check capacitors for shortening and resistors for value by means of an ohmmeter, but be aware in-circuit measurements should be evaluated carefully.

Please be aware that all measured voltages or RF levels in this document are rough figures. Especially RF levels vary due to different measuring equipment or different grounding of the probe used. When using an RF probe use a pair of metallic tweezers to connect the probe ground to the PWB ground as close to the measurement point as possible.

### ■ Receiver description and troubleshooting

Each receiver path is a direct conversion linear receiver. From the antenna, the received RF-signal is fed to a front end module where a diplexer first divides the signal into two separate paths according to the band of operation: either lower, EGSM900 or upper, GSM1800/GSM1900 path.

Most of the receiver circuitry is included in Honi.

#### ***Rx front end***

The front end features include:

- Antenna 50 ohm input
- RXs single outputs
- TXs single 50 ohm inputs
- 3 control lines from Honi

#### ***Antenna***

The RA-8 EGSM900/GSM1800/GSM1900 transceiver features an internal antenna.

**Receiver characteristics**

Item	Values (GSM900/1800/1900)
Type	Direct conversion, Linear, FDMA/TDMA
LO frequencies	3700...3840 MHz / 3610...3760 MHz / 3860...3980 MHz
Typical 3 dB bandwidth	+/- 91 kHz
Sensitivity	min. - 102 dBm
Total typical receiver voltage gain (from antenna to RX ADC )	86 dB
Receiver output level (RF level -95 dBm )	230 mVpp, single-ended I/Q signals to RX ADCs
Typical AGC dynamic range	83 dB
Accurate AGC control range	60 dB
Typical AGC step in LNA	30 dB GSM1800/GSM1900, 25 dB GSM900
Usable input dynamic range	-102 ... -10 dBm
RSSI dynamic range	-110 ... -48 dBm
Compensated gain variation in receiving band	+/- 1.0 dB

### **General instructions for Rx troubleshooting**

To start Rx troubleshooting:

1. Connect test jig to a computer with a DAU-9S cable or to a FPS-8 flash promoter with an XCS-4 modular cable.

Make sure that you have PKD-1 dongle connected to the computer's parallel port.

2. Connect a DC power supply to the module test jig with an FLC-2 cable.
3. Set the DC supply voltage to 6 V.
4. Connect an RF cable to the RF connector of the module test jig (MJ-83) and to RF signal generator.
5. Set the phone module to test jig and start Phoenix service software.
6. Initialize connection to the phone. (Use FBUS driver when using DAU-9S and COMBOX driver when using FPS-8).
7. From the File menu, choose "Choose Product".
8. From the list, select RA-8.
9. From the toolbar, set operating mode to "Local".
10. From the Testing menu, choose "RF Controls".
11. In the "RF Controls" window:

- Select band "GSM 900", "GSM 1800" or "GSM1900" (Default = "GSM900")
- Set Active unit to "Rx" (Default = "Rx")
- Set Operation mode to "Burst" (Default = "Burst")

For continuous mode:

- Set Operation mode to "Continuous"
- Set AGC to "12: FEG\_ON + DTOS\_ON + BB\_30=Vgain60" (maximum gain setting used in normal mode) (Default = "14: FEG\_ON + DTOS\_ON + BB\_42=Vgain72")
- Set Rx/Tx channel to 37 on GSM900 band, 700 on GSM1800 band or 661 on GSM1900 (Defaults)

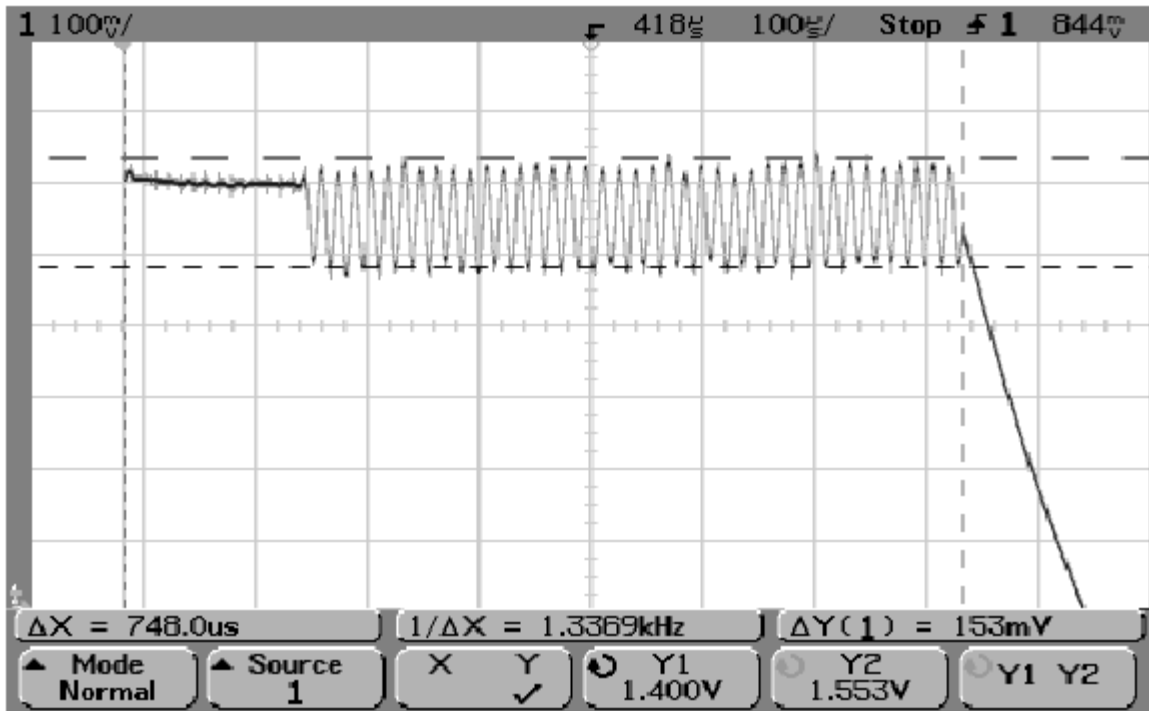
12. Apply

942.46771 MHz (channel 37 + 67.710 kHz offset),  
 1842.86771 MHz (channel 700 + 67.710 kHz offset) or  
 1960.06771 MHz (channel 661 + 67.71 kHz) -90 dBm signal

to the RF connector (remember to compensate for cable attenuation).

When measuring with an oscilloscope on "RXI" or "RXQ", you should see the following screens on a working GSM900, GSM1800 or GSM1900 receiver:

Figure 7: Rx I/Q signal, burst mode, input level -90dBm



- Receiver I or Q burst mode signal (channel 37) measured from test point RXI or RXQ with 942.46771 MHz signal, input level -90dBm at RF-connector.

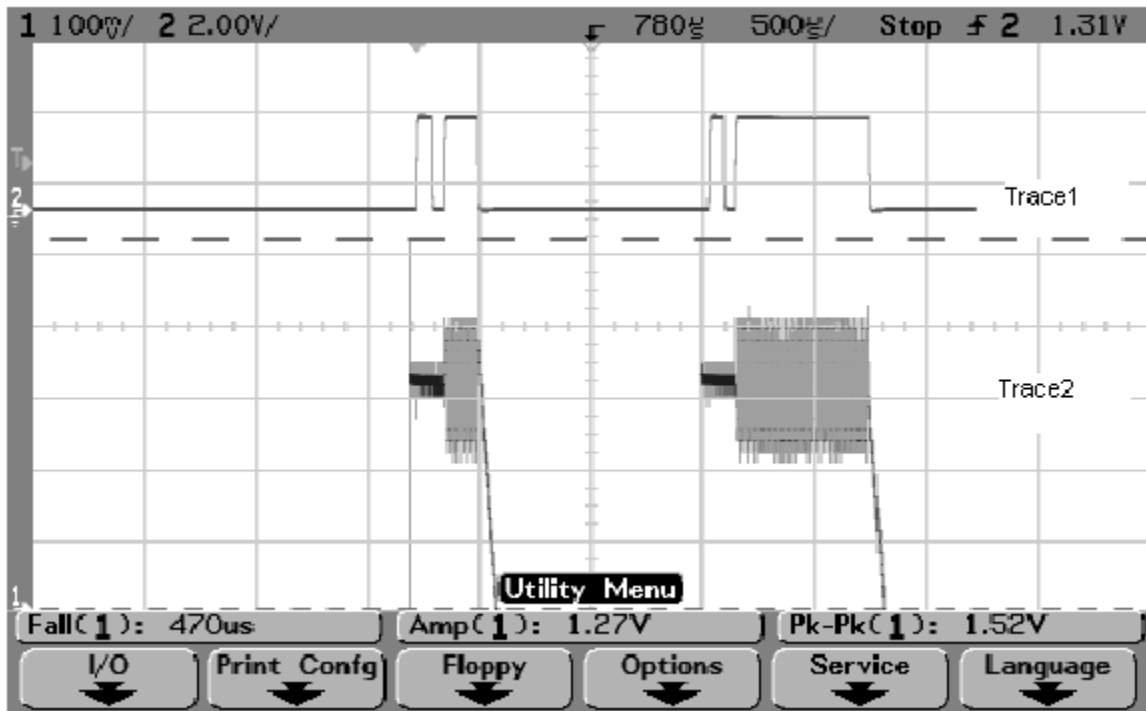
Correct signal amplitudes approximately:

- GSM900~170mVpp
- GSM1800~140mVpp
- GSM1900~160mVpp

Signal part frequency 67.7kHz sine.

DC level of signal part is 1.35V. DC level can vary about +/-100mV between I

and Q signals and between different bands as well.

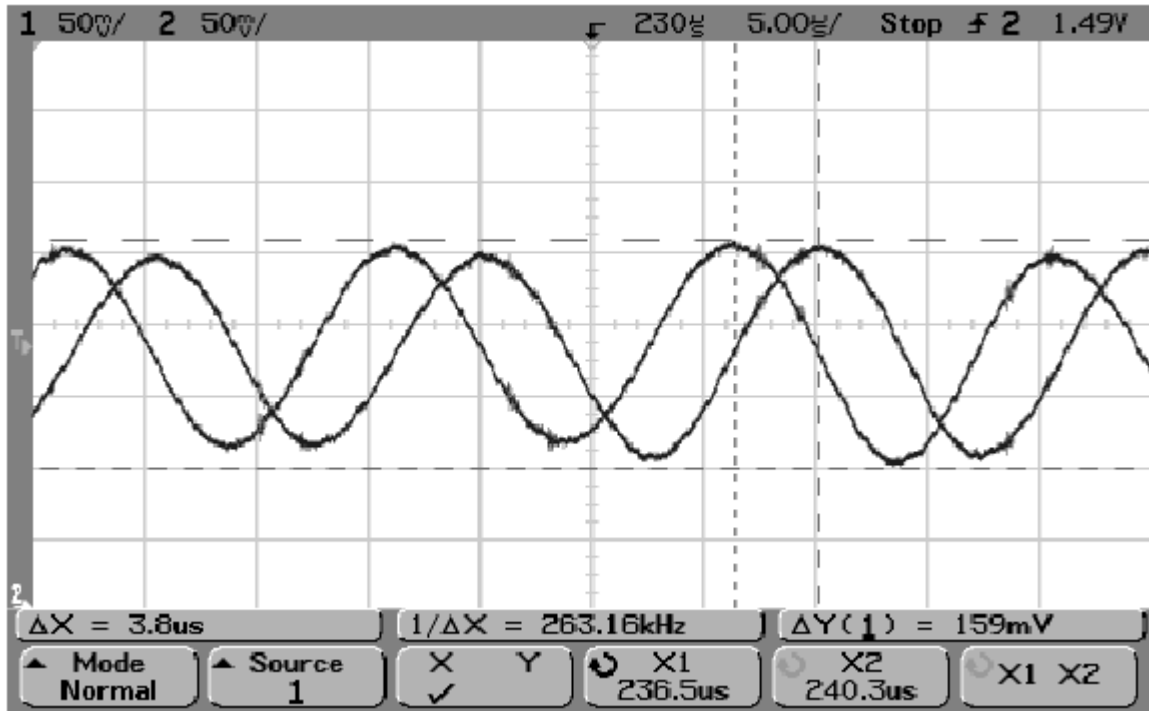


GSM1900 receiver burst mode I or Q signal at ch 661 with input signal 1960.067MHz, level -90 dBm at RF-connector.

Trace2: With wider time scaling both monitoring and own Rx bursts are seen, 1st burst (shorter) is monitoring and 2nd burst (longer) is own Rx burst.

Trace1: External LNA VCC supply voltage at burst mode, input level -90 dBm. Measured from test point LNA\_VCC

Figure 8: GSM1900 Rx I or Q signal (trace2), burst mode.



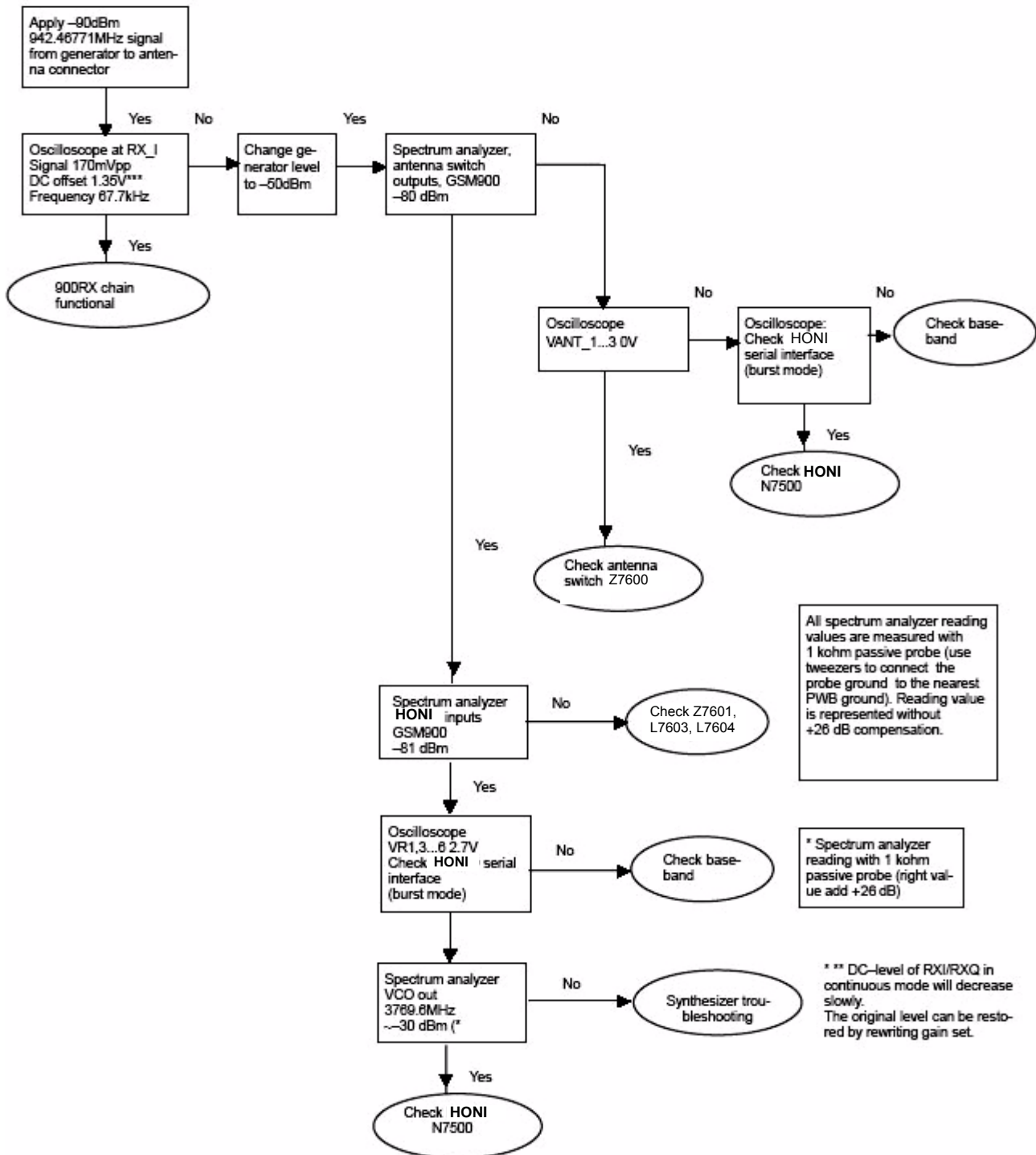
Detailed view of GSM900 continuous mode Rx I and Q signals measured from test points RXI and RXQ simultaneously.

Used channel 37, input signal 942.46771 MHz, level -90 dBm at antenna port, AGC setting 12.

Phase difference should be 90 degrees between Rx I and Q signals at all bands.

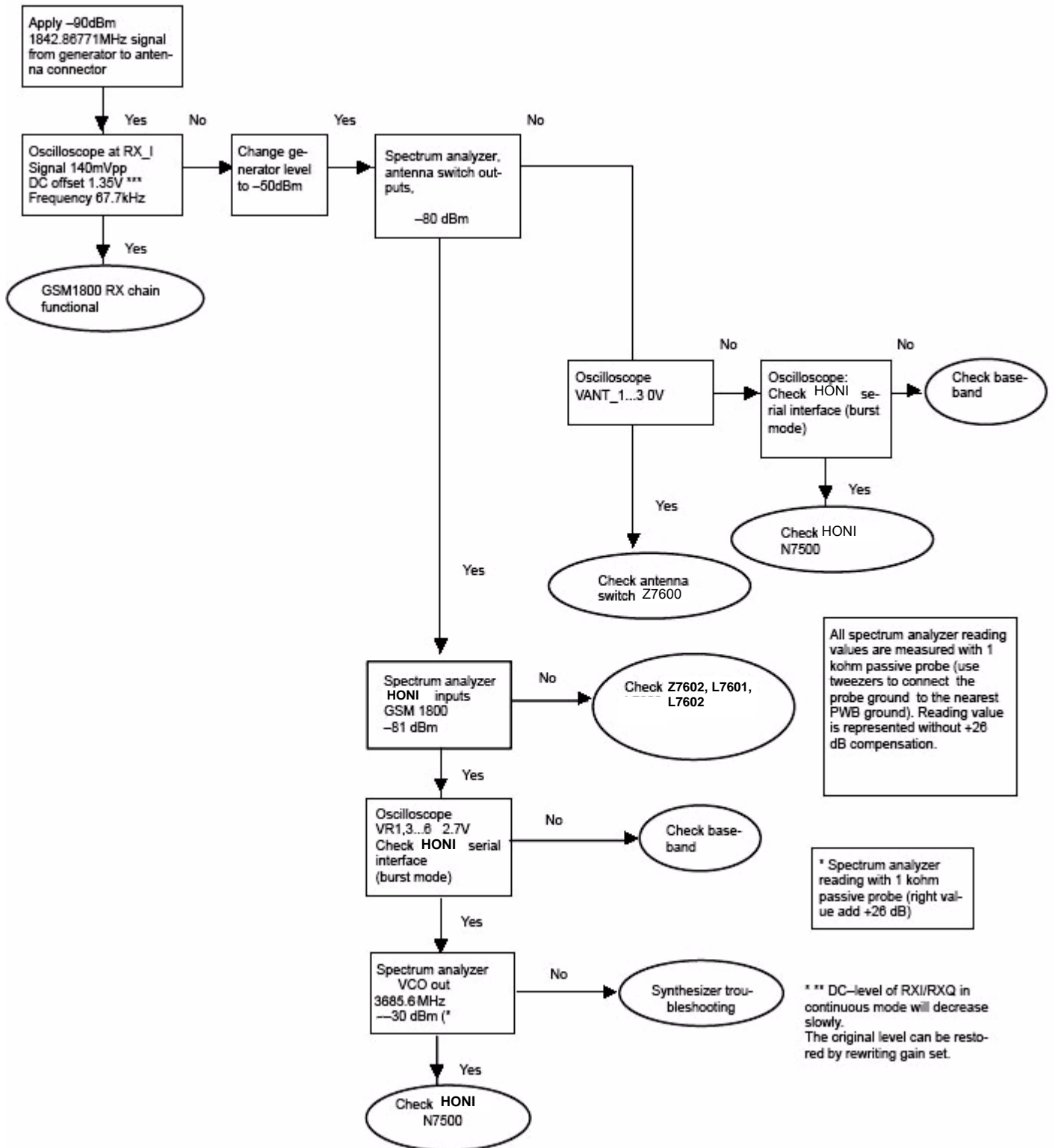
**Troubleshooting diagram for GSM900 receiver**

Phone in "Continuous" mode, AGC setting "12".



**Troubleshooting diagram for GSM1800 receiver**

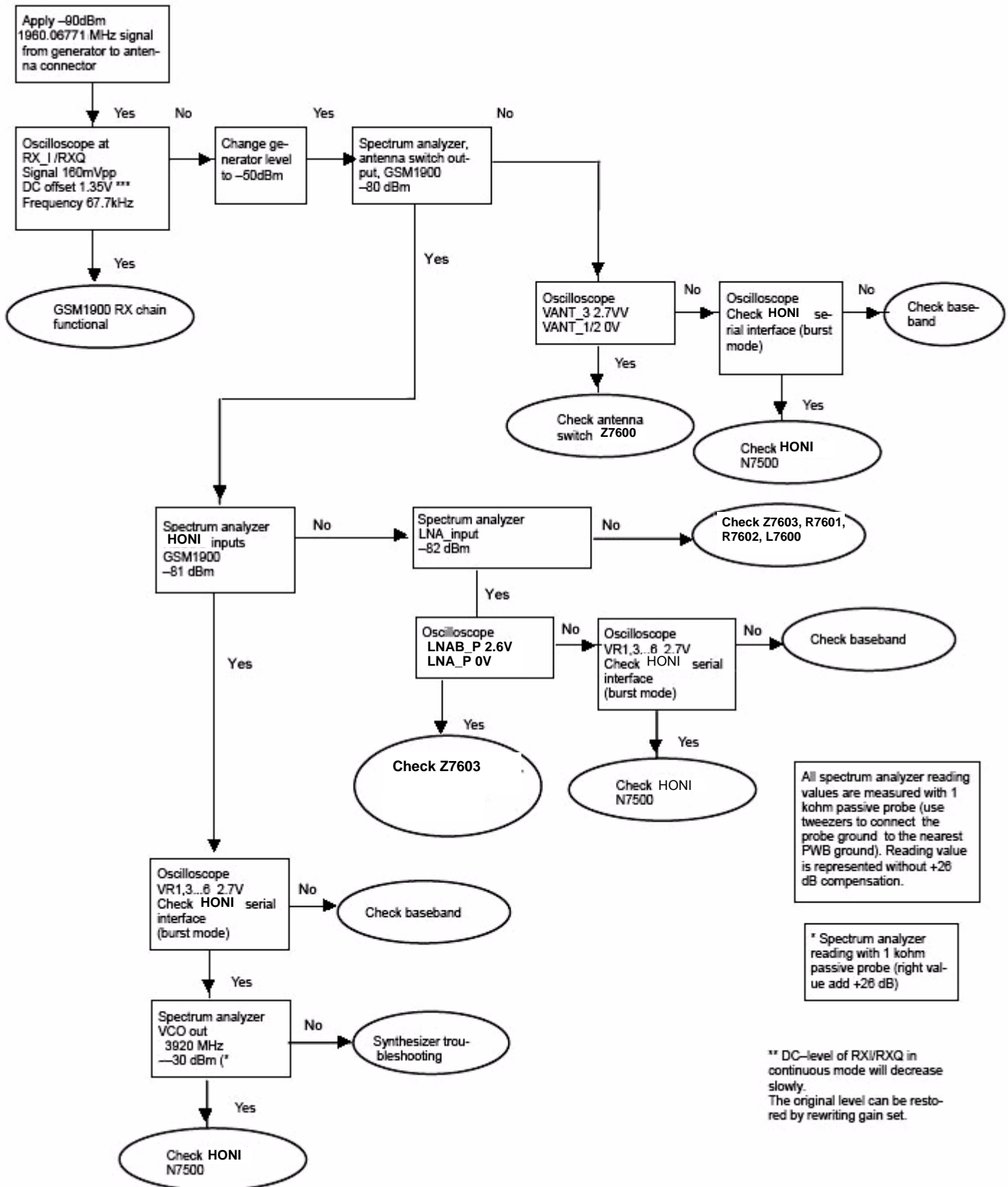
Phone in "Continuous" mode, AGC setting "12.





**Troubleshooting diagram for GSM1900 receiver**

Phone in "Continuous" mode, AGC setting "12."



**■ Transmitter description and troubleshooting**

The transmitter consists of:

- two final frequency IQ-modulators
- two power amplifiers, for the lower and upper bands separately
- power control loop.

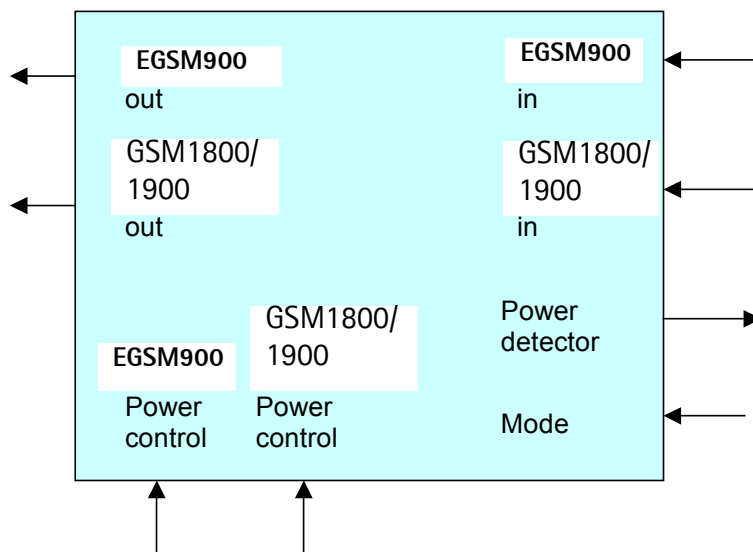
The IQ-modulators are integrated in Honi, as well as the operational amplifiers of the power control loop. The two power amplifiers are located in a single module with a power detector. In the GMSK mode, the power is controlled by adjusting the DC bias levels of the power amplifiers.

***Power amplifier***

The power amplifier features include:

- 50 ohm input and output, EGSM900/GSM1800/GSM1900
- internal power detector
- EDGE mode

**Figure 9: Power amplifier**



***RF ASIC Honi***

The RF ASIC features include

- Package LFGBGA88
- Balanced I/Q demodulator and balanced I/Q modulator
- Power control operational amplifier, acts as an error amplifier
- The signal from VCO is balanced, frequencies 3296 to 3980 MHz

- EGSM900 and GSM1800 low noise amplifier (LNA) are integrated.
- IPAD substrate, including integrated coils, resistors and capacitors

The Honi can be tested by test points only.

### **AFC function**

AFC is used to lock the transceiver's clock to the frequency of the base station.

### **Transmitter characteristics**

Item	Values (EGSM900/1800/1900)
Type	Direct conversion, nonlinear, FDMA/TDMA
LO frequency range	3520...3660 MHz / 3420...3570 MHz / 3700...3820 MHz
Output power GMSK	33 / 30 / 30 dBm 2 W / 1W peak
Output power 8-PSK	27 / 26 / 26 dBm 0.5 W / 0.4 W peak
Gain control range	min. 30 dB
Maximum phase error (RMS/peak) GMSK Maximum EVM (RMS/peak) 8-PSK	max 5 deg./20 deg. Peak max 10% / 30%

### **General instructions for Tx troubleshooting**

Please refer to section Service Concepts in Chapter 3, Service Software Instructions.

To start Tx troubleshooting:

1. Connect the test jig MJ-83 to a computer with a DAU-9S cable or to an FPS-8 flash prommer with an XCS-4 modular cable.

Make sure that you have a PKD-1 dongle connected to the computer's parallel port.

2. Connect a DC power supply to the module test jig (MJ-83) with an FLC-2 cable.

*Note: When repairing or tuning the transmitter use external DC supply with at least 3A current capability. Set the DC supply voltage to 3.9V and set the jumper connector on test jig to "bypass" position.*

3. Connect an RF cable to the RF connector of the module test jig (MJ-83) and measurement equipment; or at least a 10dB attenuator, otherwise the PA may be damaged. Use a spectrum analyzer as measurement equipment.

*Note: The maximum input power of a spectrum analyzer is +30dBm. It is recommended to use 10dB attenuator on the spectrum analyzer input to prevent any damage.*

4. Set the phone module to test jig and start Phoenix service software.
5. Initialize connection to the phone. (Use FBUS driver when using DAU-9S and COMBOX driver when using FPS-8).

6. To choose a product in Phoenix:

From the File menu, choose "Choose Product" and select RA-8 from the list  
or

from the File menu, choose "Scan Product".

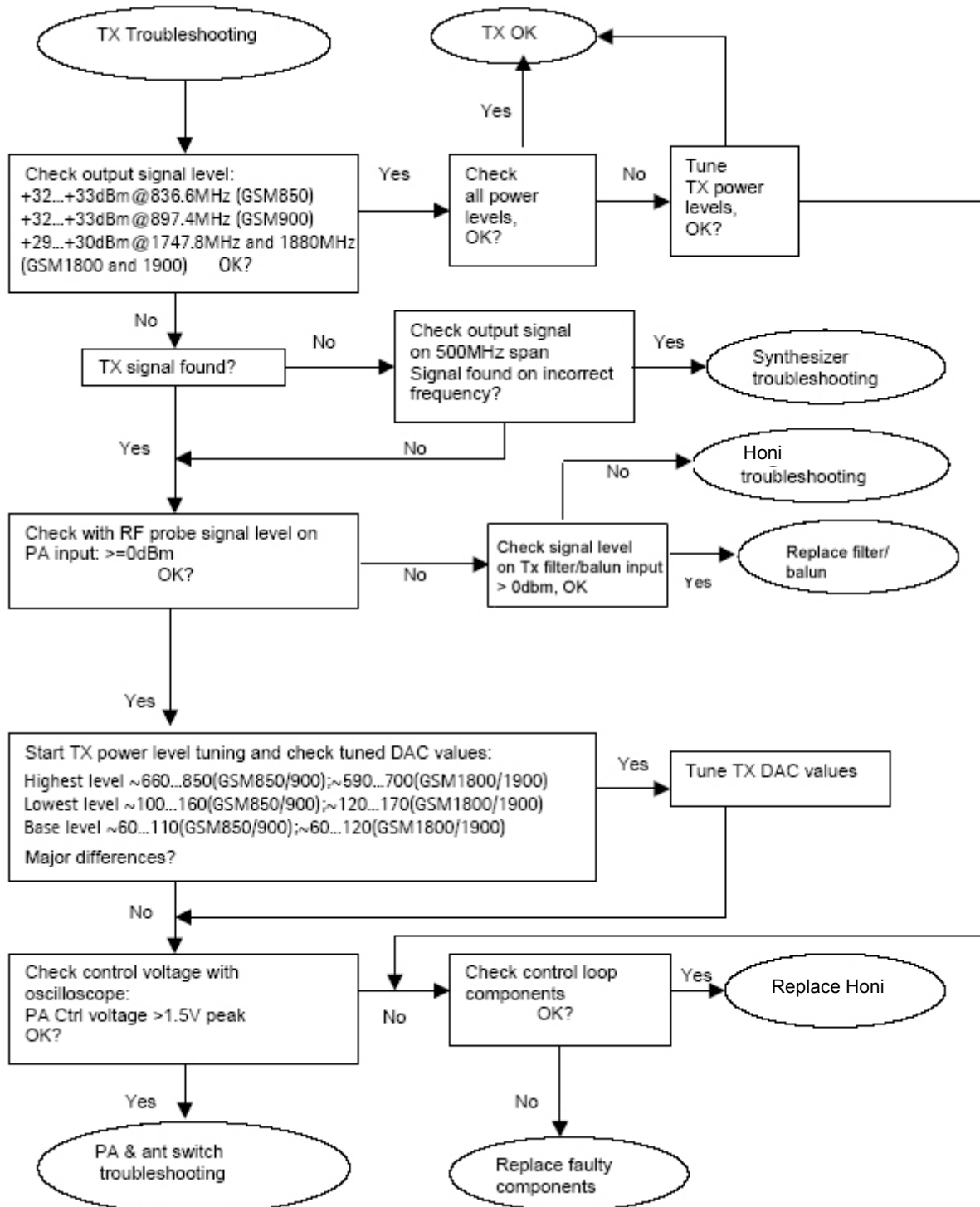
7. From the toolbar, set operating mode to "Local".

8. From the Testing menu, choose "RF Controls".

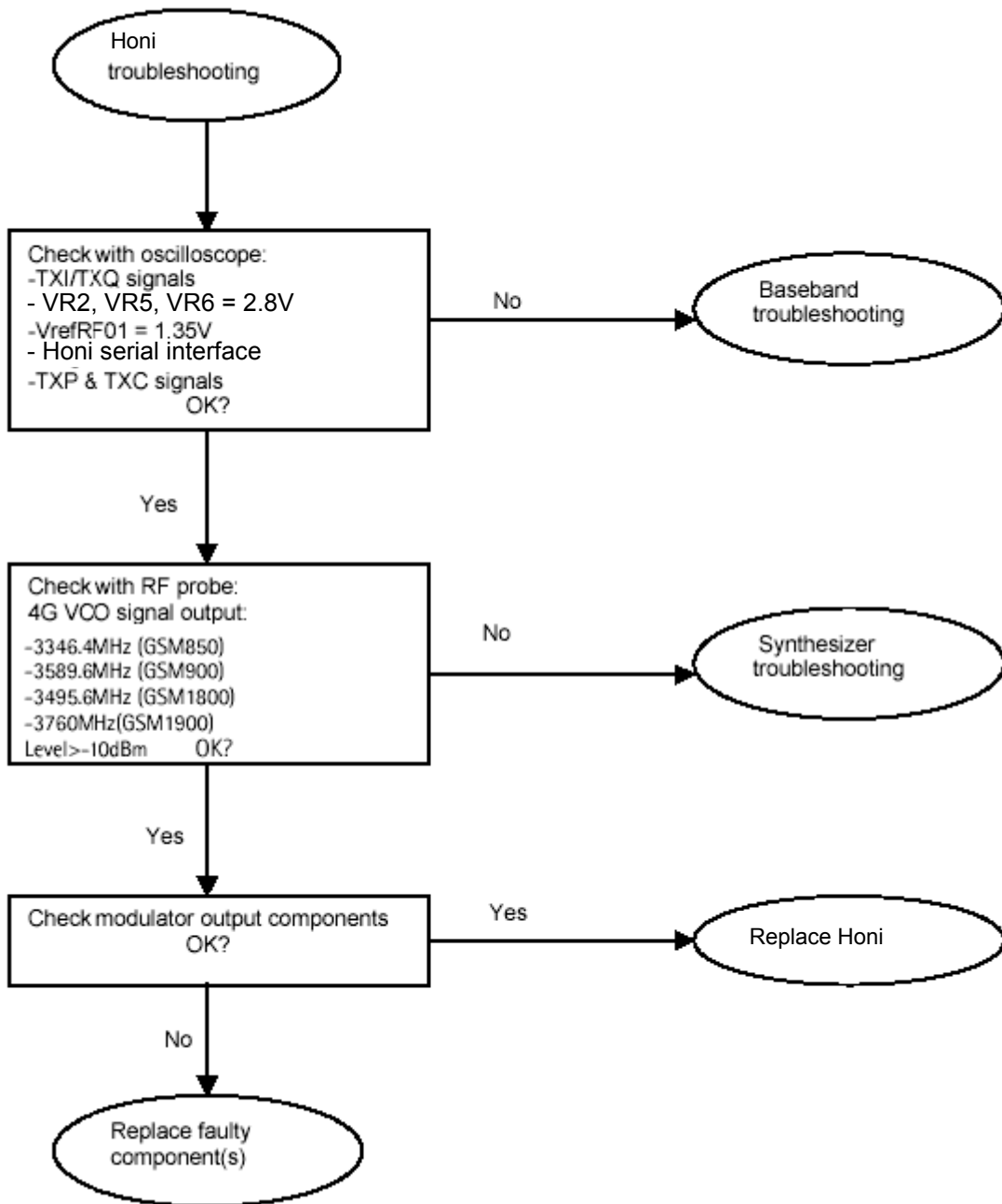
9. In the "RF Controls" window:

- Select band "GSM900" or "GSM 1800" or "GSM1900" (Default = "GSM900").
- Set Active unit to "Tx" (Default = "Rx").
- Set Operation mode to "Burst" (Default = "Burst").
- Set Tx data type to "Random" (Default = "All1").
- Set Rx/Tx channel to 37 on GSM900 band or 700 on GSM1800 band or 661 on GSM1900 (Defaults).
- Set Tx PA mode to "Free" (Default).
- Set power level to 5 (Default = 19) on GSM900 or to 0 (Default = 15) on GSM1800 or GSM1900.

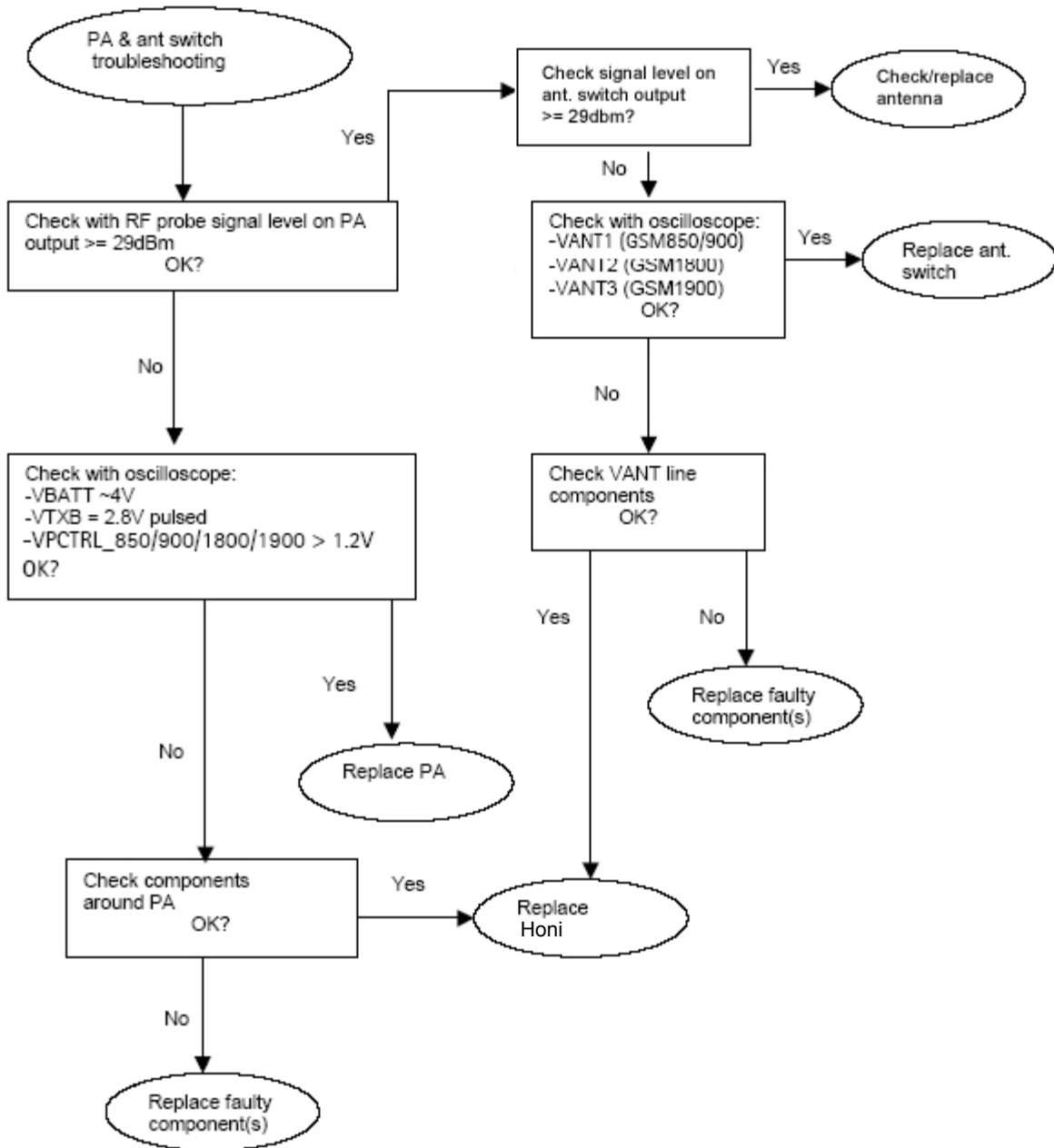
**Transmitter troubleshooting diagram**



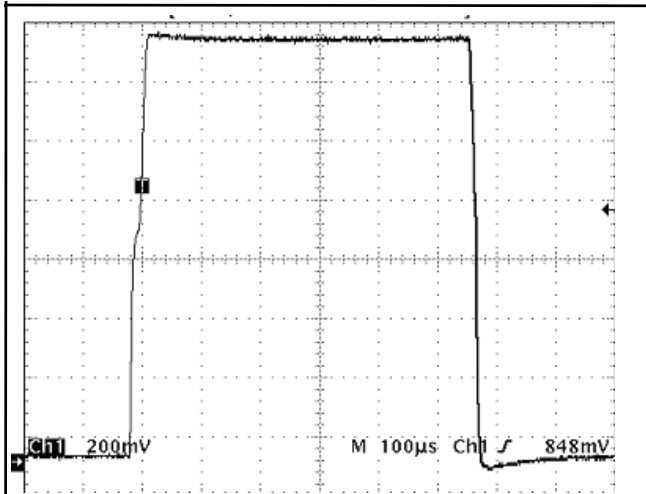
Honi IC troubleshooting diagram



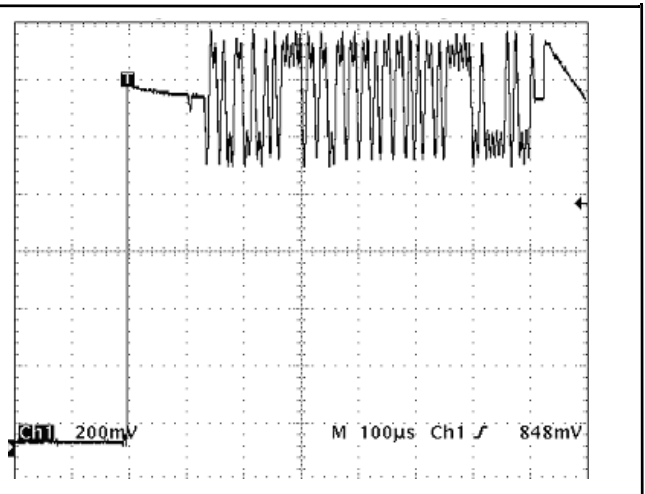
**PA and antenna switch troubleshooting diagram**



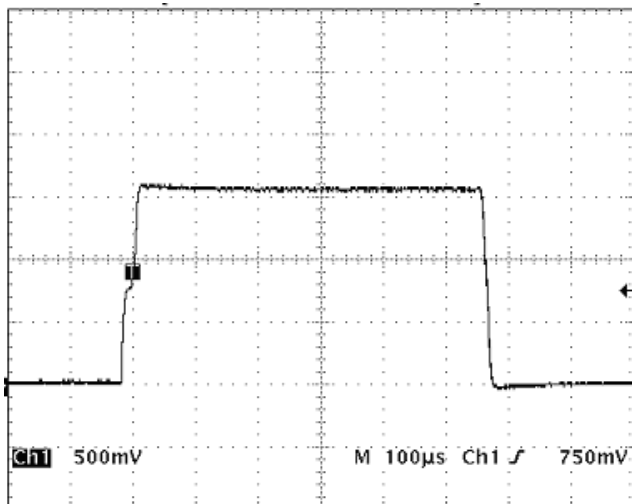
Pictures of transmitter signals



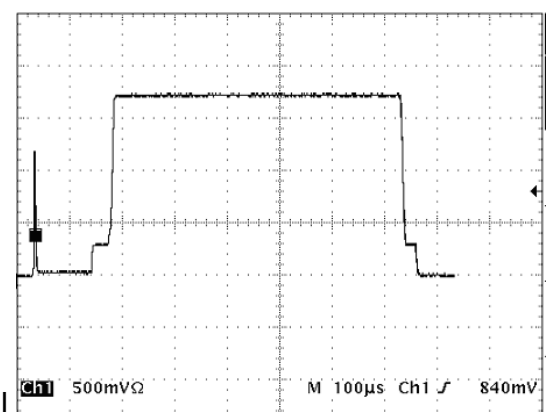
VPCTRL 850/900 power level 5 at R7703/C7703  
VPCRTL\_1800/1900 power level 0 at R7704/C7704



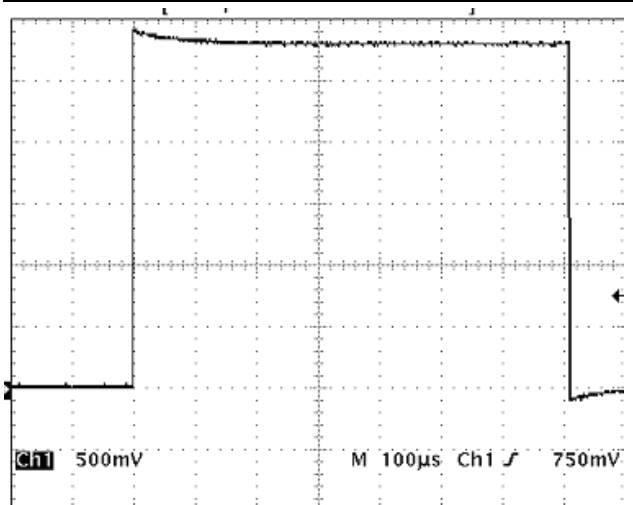
TXI/TXQ TX signals at R7516/R7515/C7535/C7536



VTXB 850/900 at C7713 VTXB\_1800/1900 at C7714



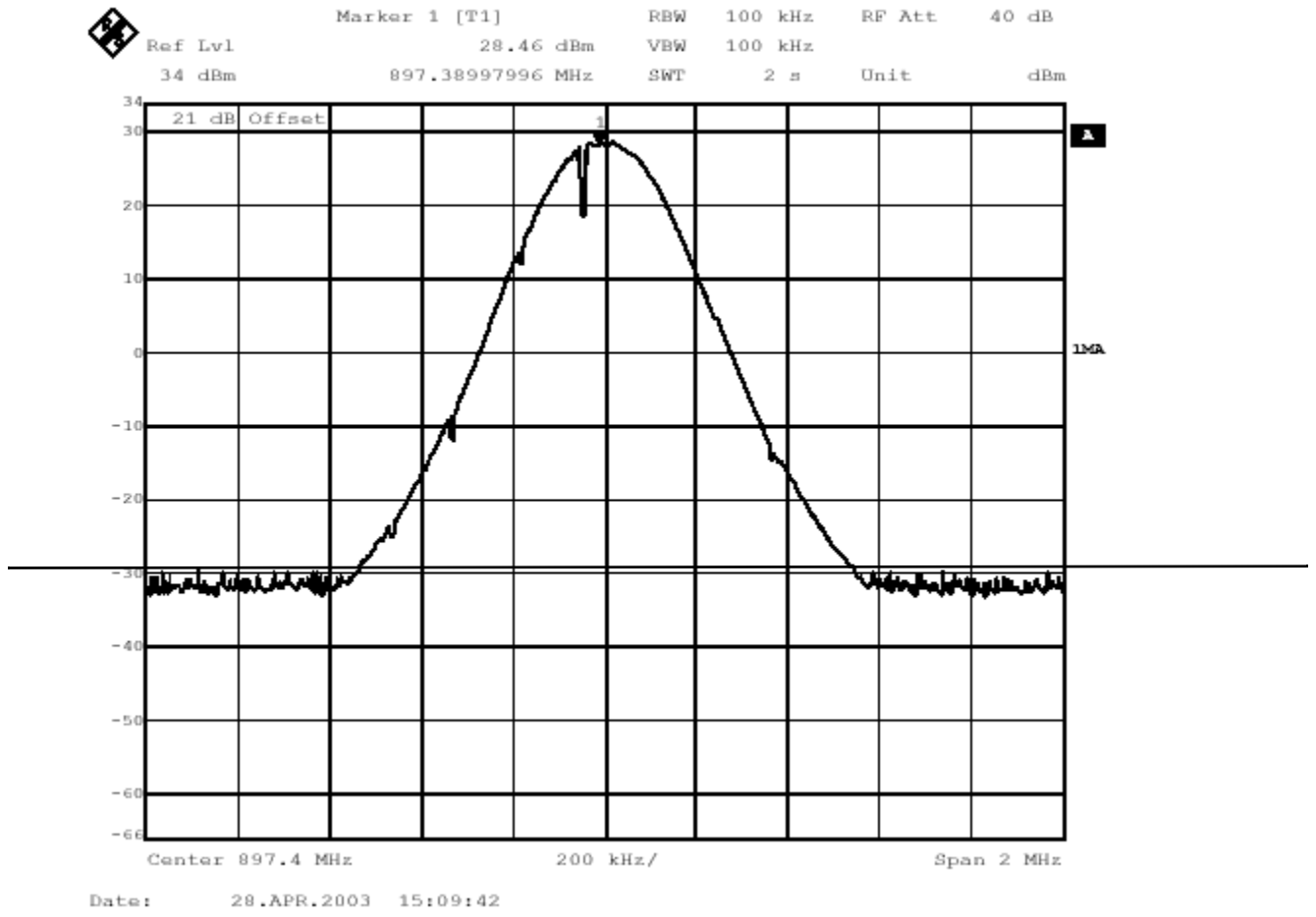
TXC 850/900 power level 5 at R7522



VANT\_1 at C7805 VANT\_2 at C7804  
VANT\_3 at C7538



**Figure 10: Tx out signal, 900 band burst mode, channel 37**



**■ Additional information for EDGE troubleshooting**

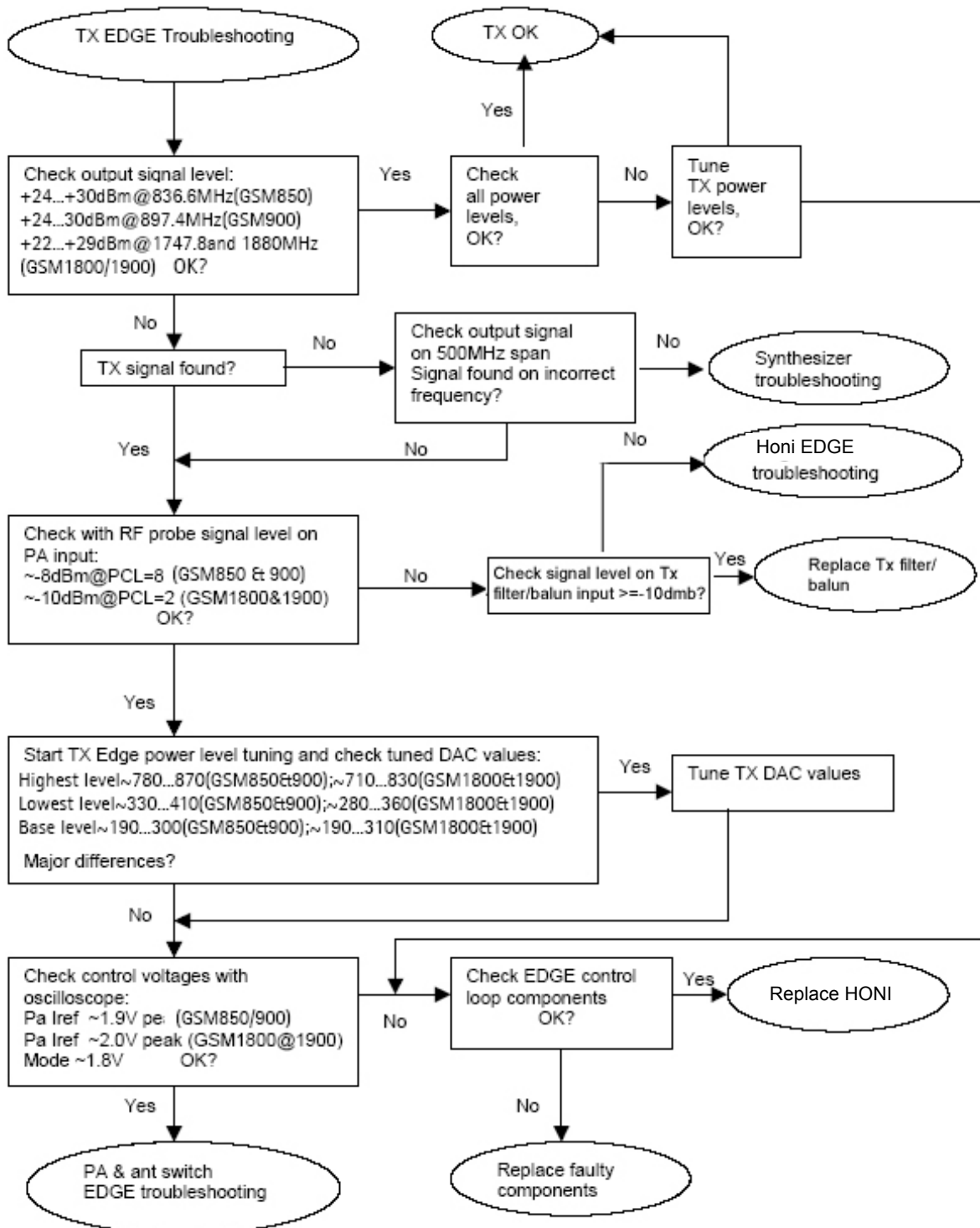
*Note! EDGE mode troubleshooting differs slightly from basic GSM troubleshooting.*

To start EDGE troubleshooting:

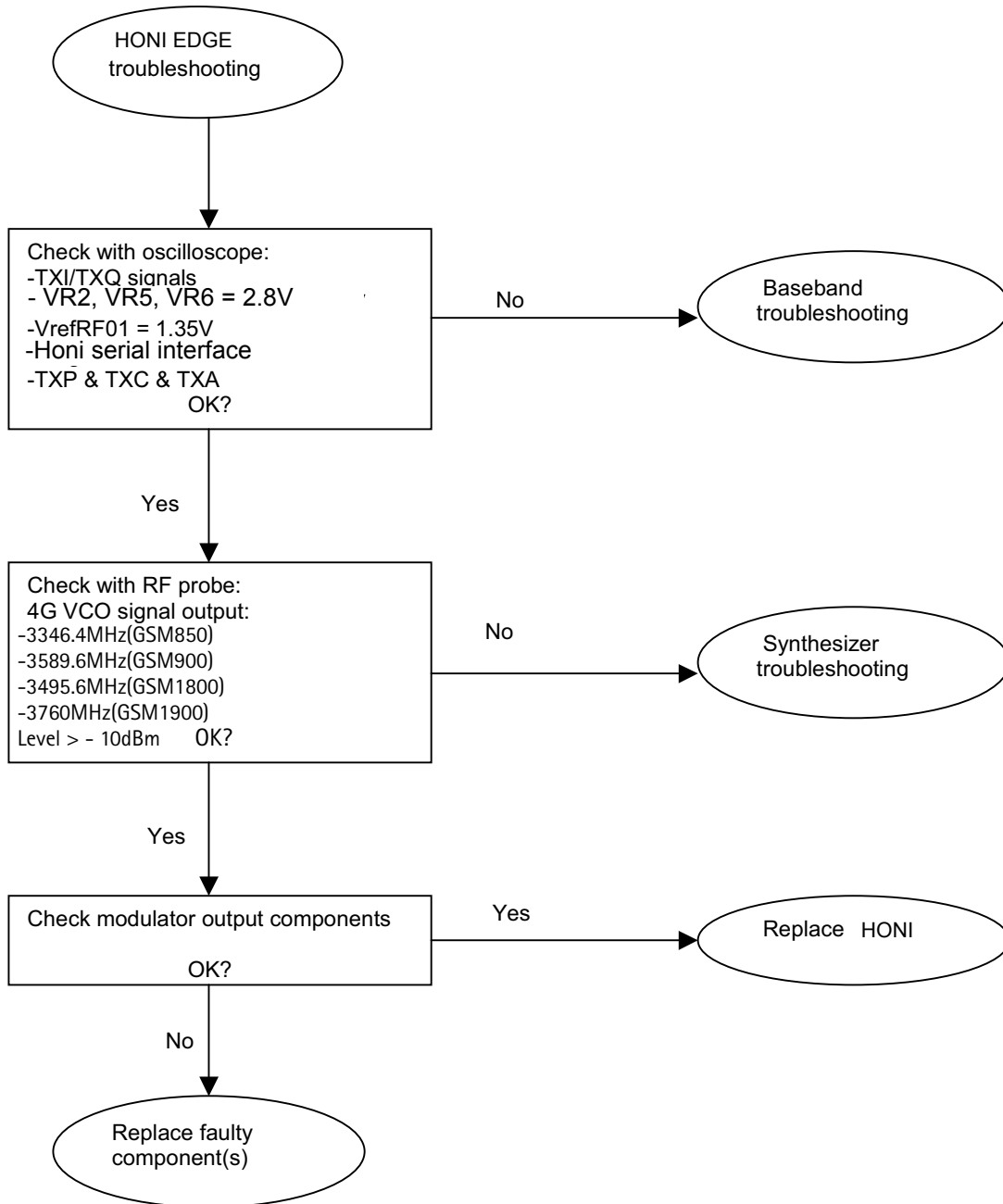
1. Initialize a connection to the phone (see GSM900/1800/1900 troubleshooting instructions).
2. To select a product in Phoenix:  
From the File menu, choose "Choose Product" and select RA-8 from the list  
or  
from the File menu, choose "Scan Product".
3. From the toolbar, set operating mode to "Local"
4. From the Testing menu, choose "RF Controls".
5. In the "RF Controls" window:
  - Select Band "GSM900" or "GSM1800" or "GSM1900" (Default = "GSM900").
  - Set Active unit to "Tx" (Default="Rx").
  - Set Edge "On" (Default="Off").
  - Set Operation mode to "Burst" (Default="Burst").
  - Set Tx data type to "Alternate PN9" (Default="All1").
  - Set Rx/Tx channel to 37 on GSM900 or 700 on GSM1800 or 661 on GSM1900 (Defaults).
  - Set power level to 8 (Default = 19) on GSM900 or to 2 (Default = 0) on GSM1800 or GSM1900.

*Note! For GSM900 Edge power levels 5, 6 and 7 are not in use and for GSM1800&1900 Edge power levels 0 and 1 are not in use.*

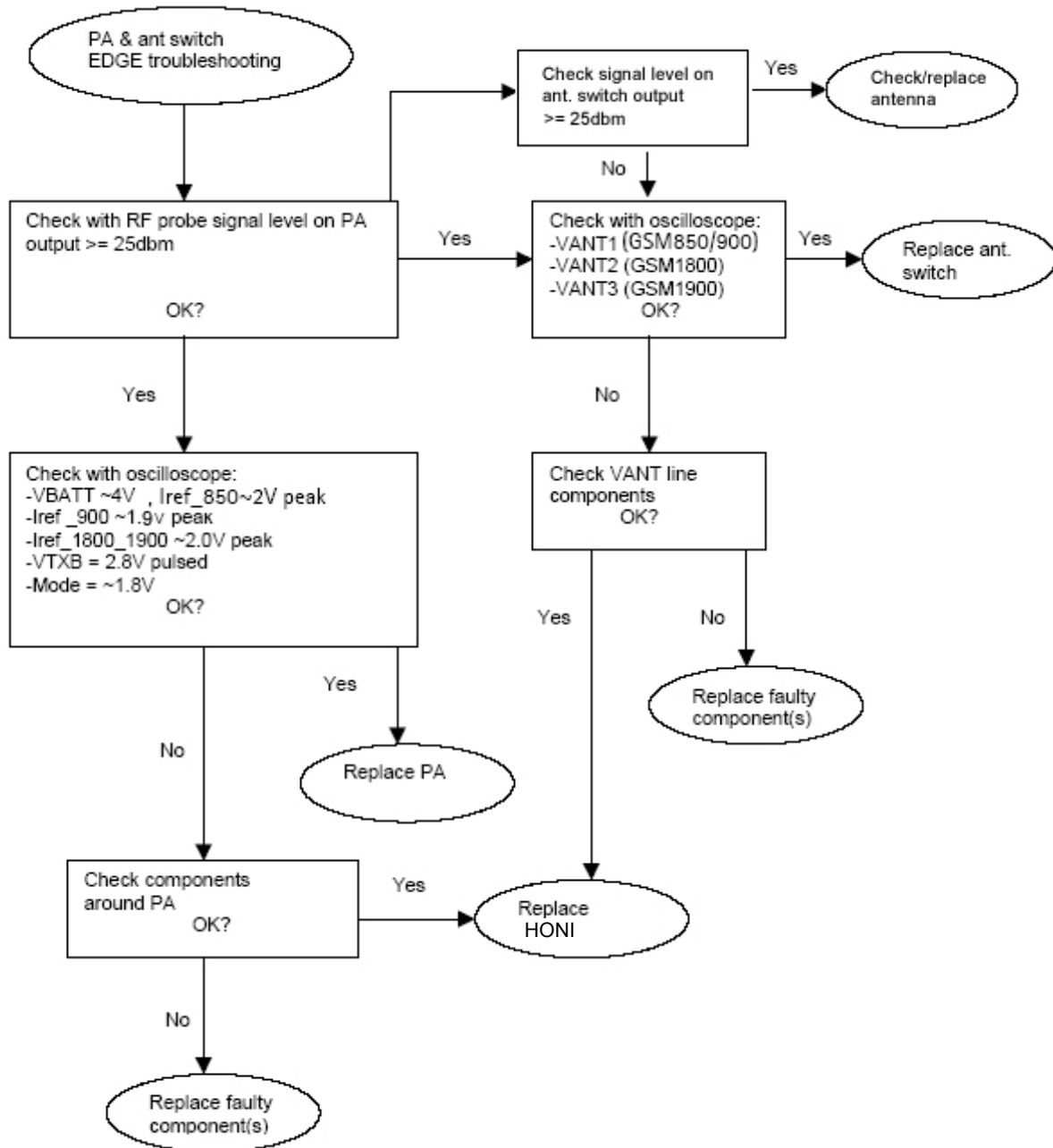
**Transmitter EDGE troubleshooting diagram**



Honi EDGE troubleshooting diagram

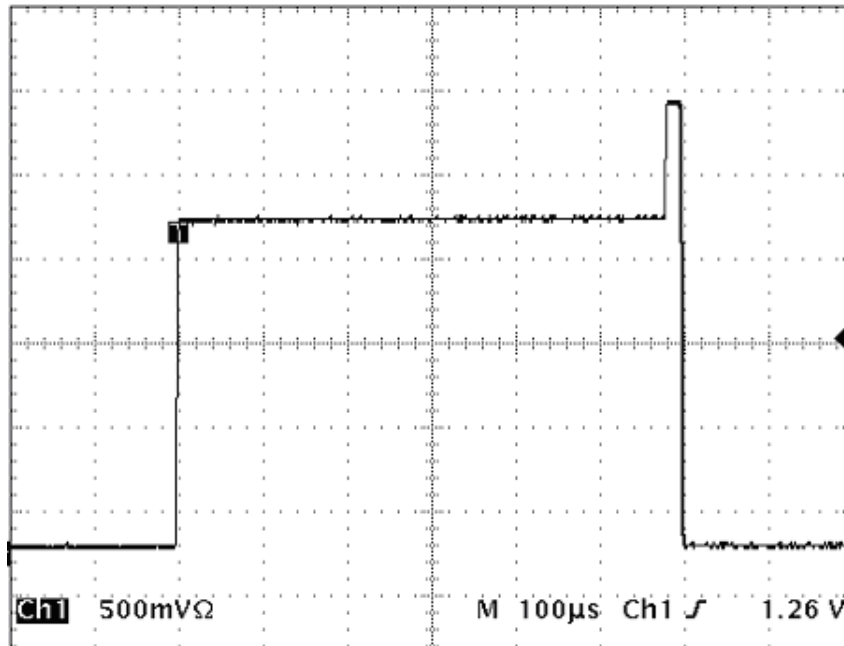


**PA and antenna switch EDGE troubleshooting diagram**

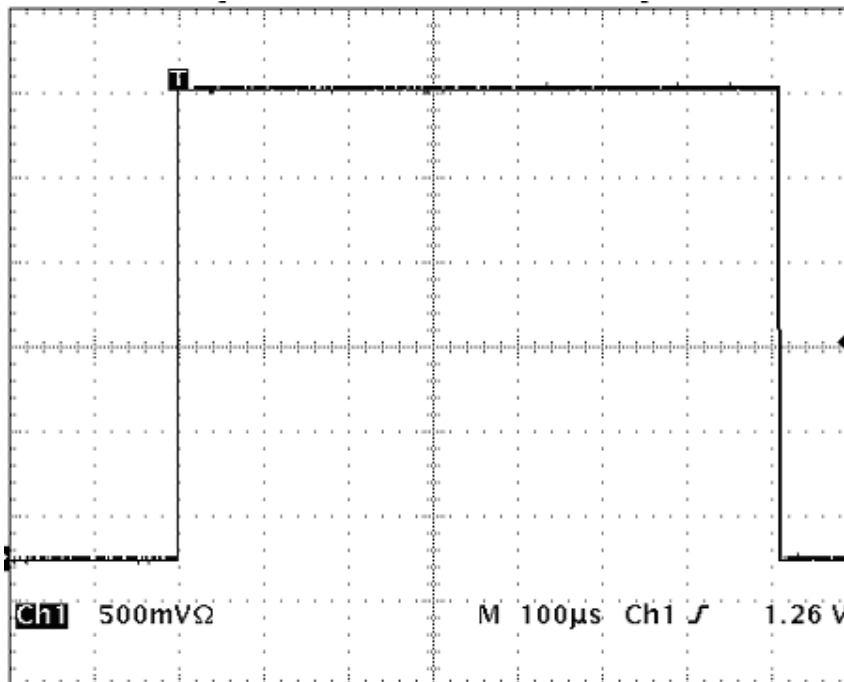


**Pictures of EDGE transmitter signals**

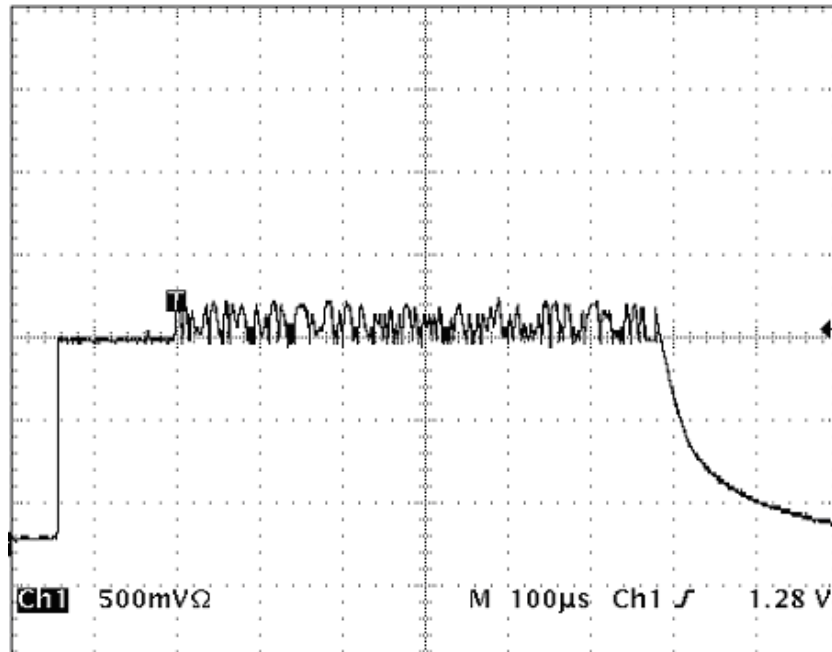
**Figure 11: I\_ref\_1800/1900 power level 2 at R7700/C7700**



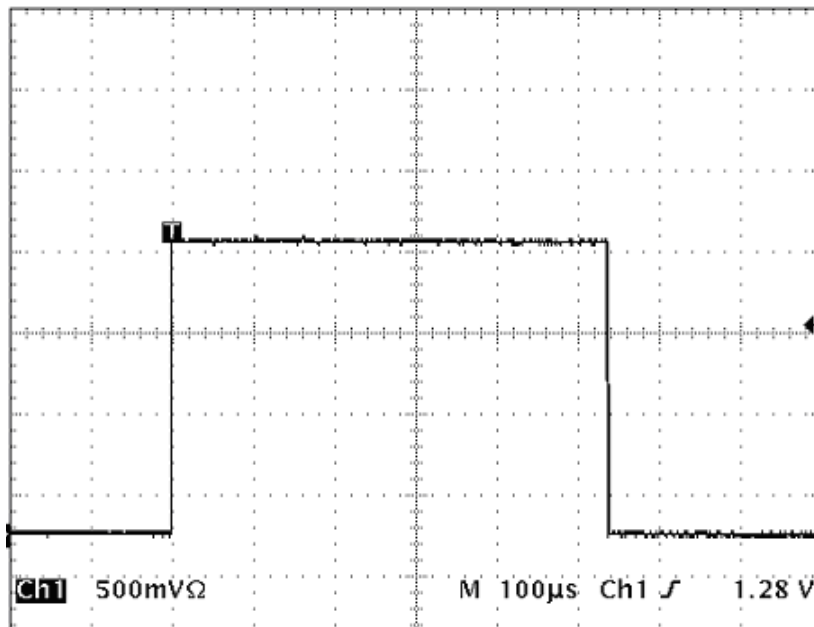
**Figure 12: VTXB 1800/1900 power level 2 at C7714**



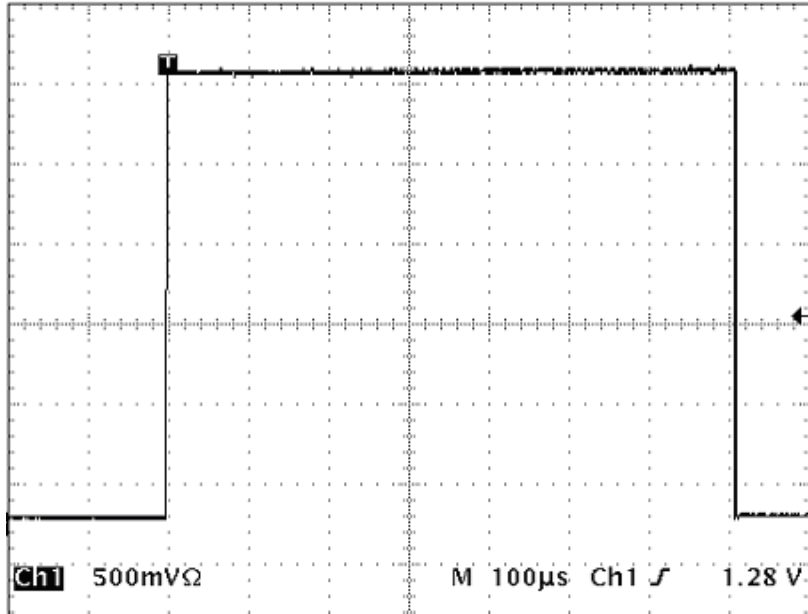
**Figure 13: TXI/TXQ signal at C7535/C7536/R7516/R7517**



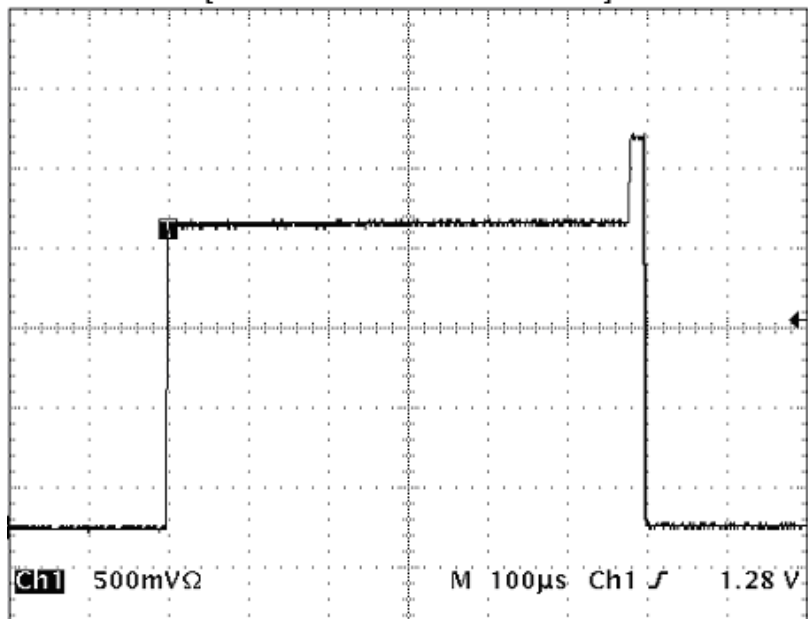
**Figure 14: TXA 900/1800/1900 at C7538**



**Figure 15: VTXB 900 power level 8 at C7713**

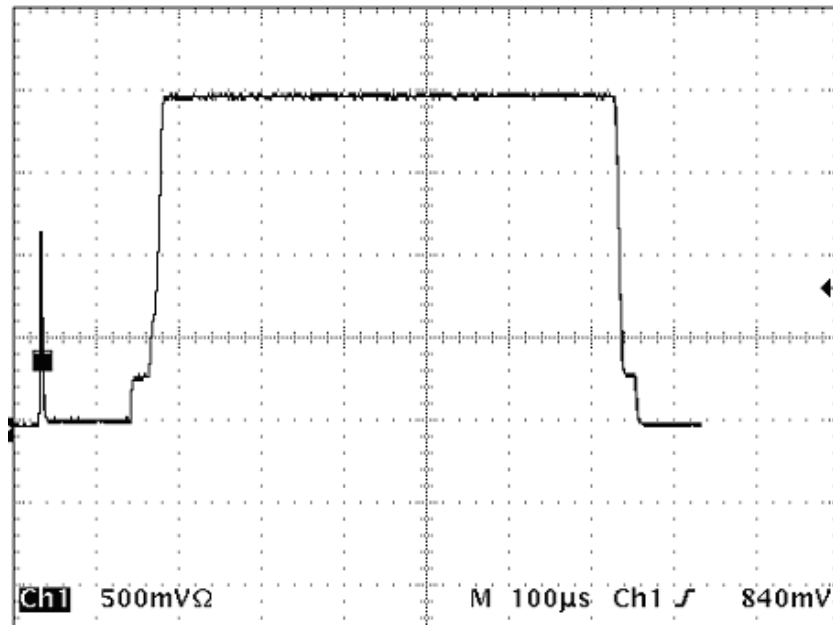


**Figure 16: I\_ref 900 power level 8 at R7701/C7701**





**Figure 17: TXC 900 power level 8 at 7522**



## ■ Synthesizer description and troubleshooting

### *Frequency synthesizers*

The VCO frequency is locked by a PLL (phase locked loop) into a stable frequency source given by a VCTCXO which is running at 26 MHz. The frequency of the VCTCXO is in turn locked into the frequency of the base station with the help of an AFC voltage which is generated in UEM by an 11 bit D/A converter. The PLL is located in Honi and it is controlled through the RF-Bus.

The required frequency dividers for modulator and demodulator mixers are integrated in Honi. Loop filter filters out the comparison pulses of the phase detector and generates a DC control voltage to the VCO. The loop filter determines the step response of the PLL (settling time) and contributes to the stability of the loop.

The frequency synthesizer is integrated in Honi except for the VCTCXO, VCO, and the loop filter.

### *General instructions for synthesizer troubleshooting*

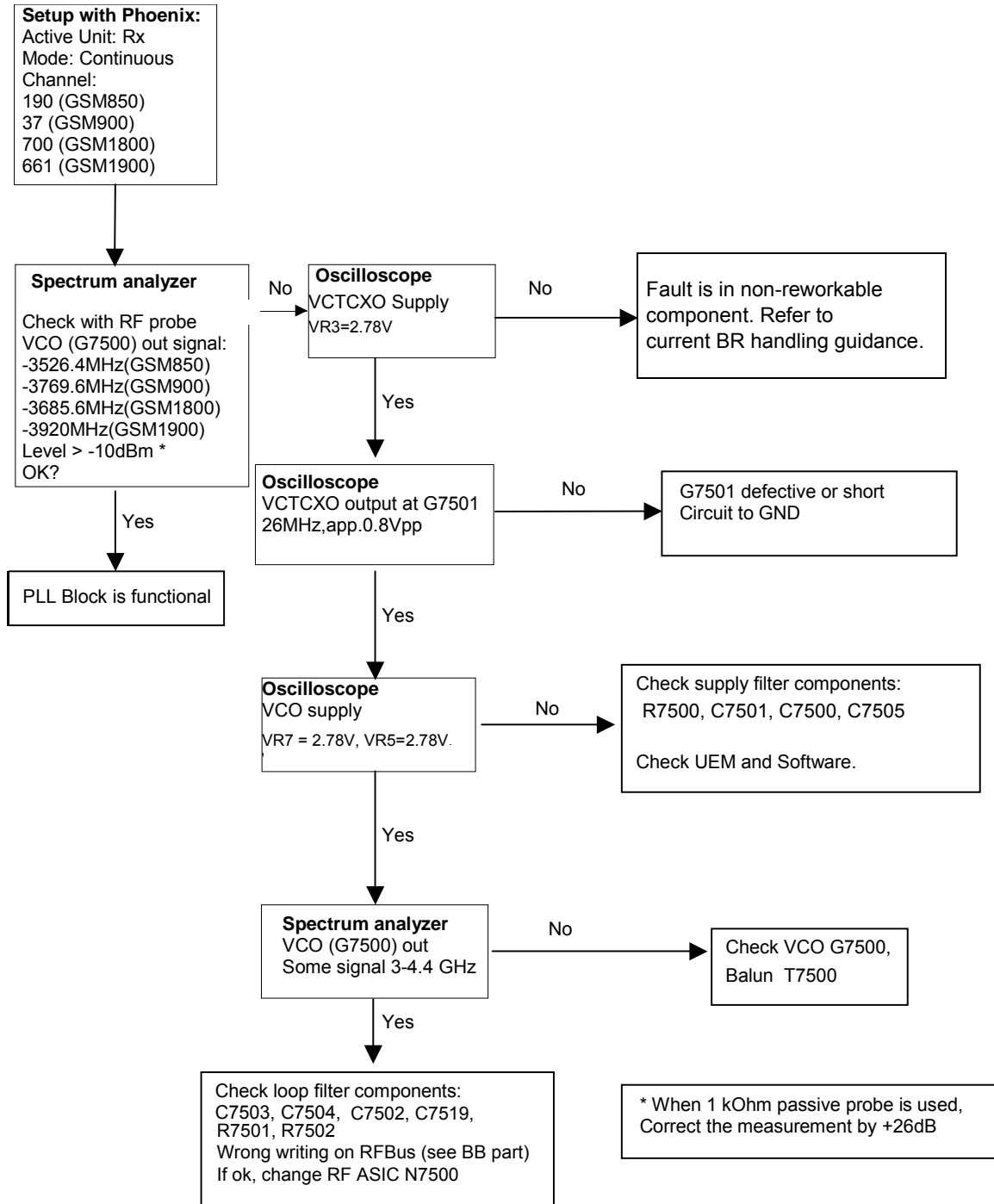
To start synthesizer troubleshooting:

1. Connect the test jig (MJ-83) to a computer with a DAU-9S cable or to an FPS-8 flash prommer with an XCS-4 modular cable.

Make sure that you have a PKD-1 dongle connected to the computer's parallel port.

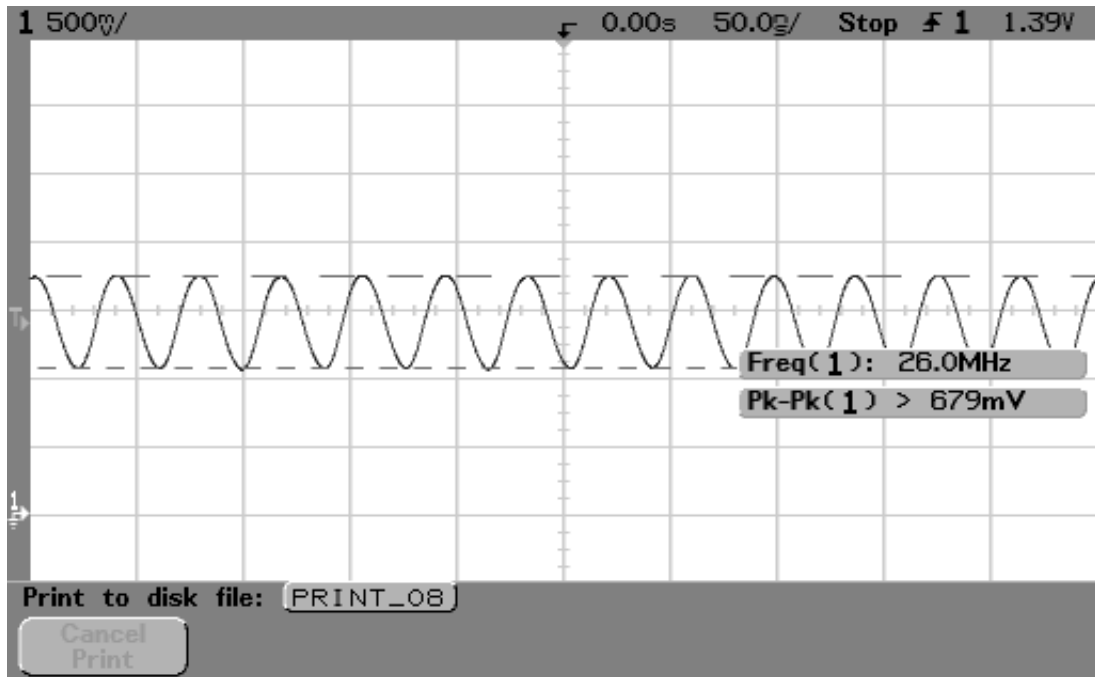
2. Connect a DC power supply or FPS-8 to the module test jig with a PCS-1 cable.
3. Set the DC supply voltage to 3.6V and set the jumper connector on test jig to "bypass" position.
4. Set the phone module to test jig and start Phoenix service software
5. Initialize connection to the phone. (Use FBUS driver when using DAU-9S and COMBOX driver when using FPS-8).
6. From the File menu, choose "Choose Product".
7. From the list, select RA-8.
8. From the toolbar, set operating mode to "Local"
9. From the Testing menu, choose "RF Controls".
10. In the "RF Controls" window:
  - Select band "GSM900", "GSM 1800" or "GSM1900" (Default = "GSM900").
  - Set Active unit to "Rx" (Default = "Rx").
  - Set Operation mode to "Continuous" (Default = "Burst").
  - Set Rx/Tx channel to 37 on GSM900 band, 700 on GSM1800 band, 661 on GSM1900 band (Defaults).

**Troubleshooting diagram for synthesizer**

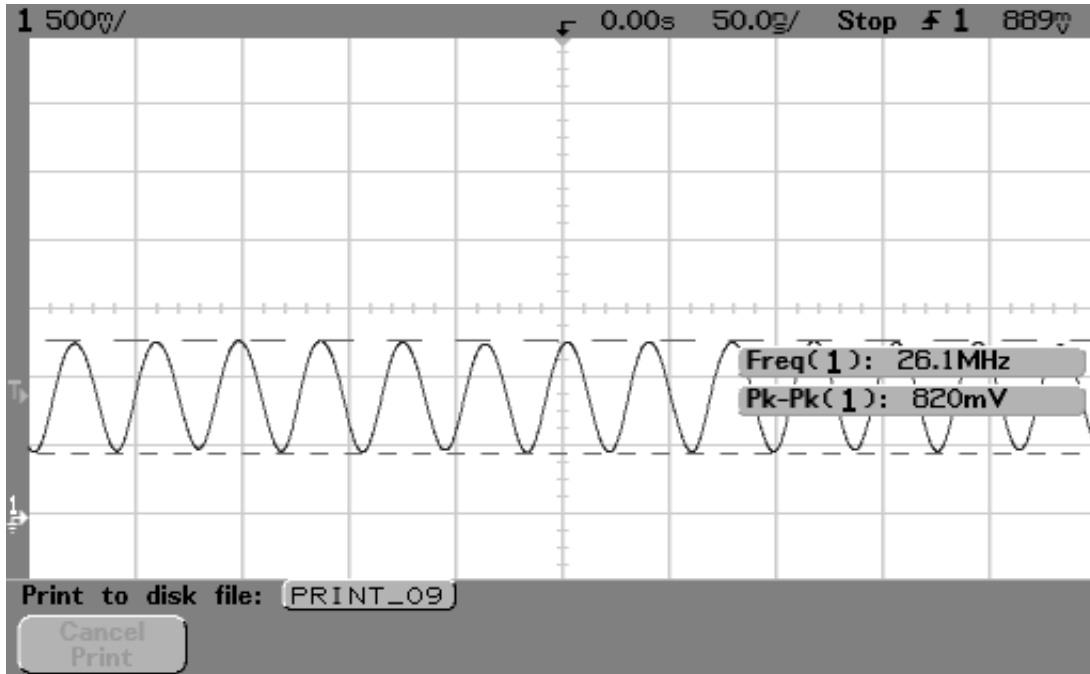


**Pictures of synthesizer signals**

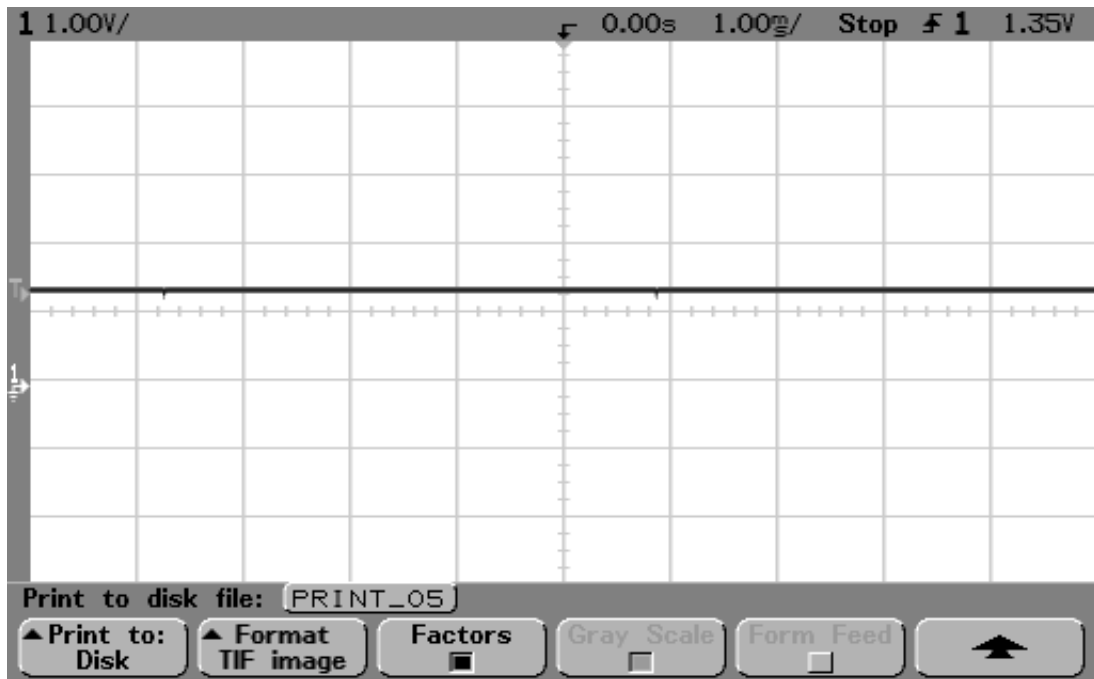
**Figure 18: 26MHz at G501 pin out**



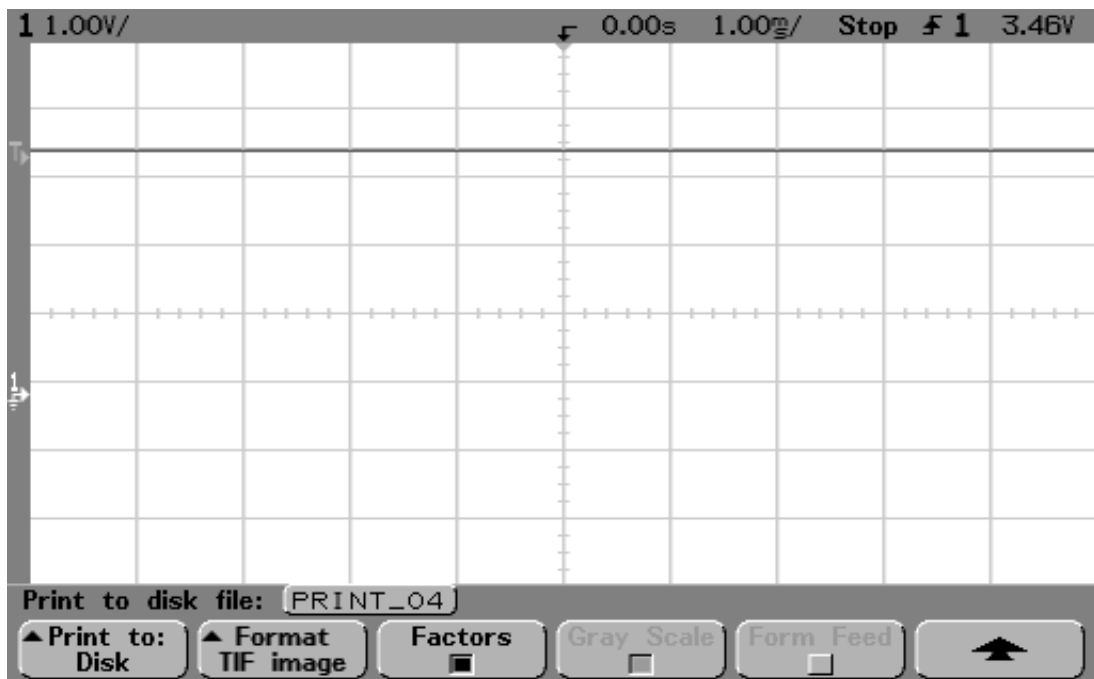
**Figure 19: 26MHz RFCLK at R420/C420**



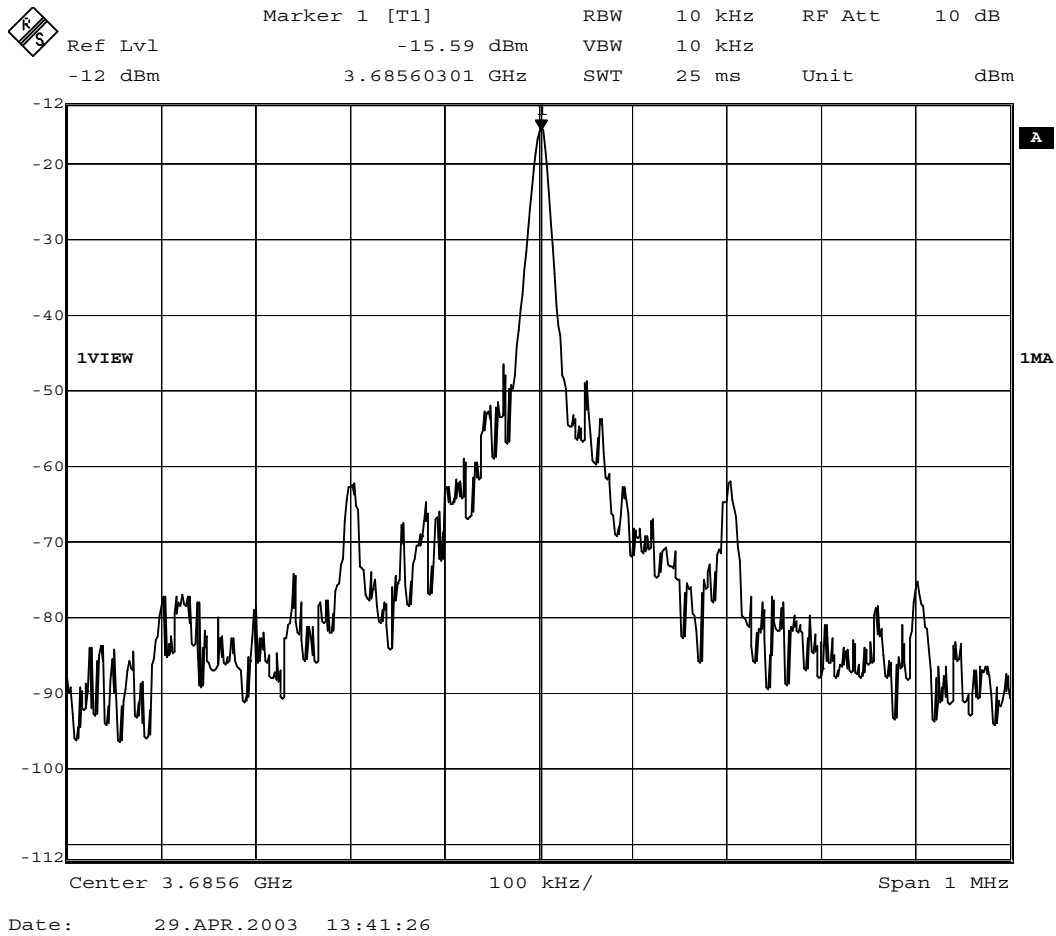
**Figure 20: 1800 Tx, channel 512, burst mode**



**Figure 21: 1900 Rx, channel 810, continuous mode**



**Figure 22: VCO output, 1800 band, ch700, Rx on, continuous output**



## Frequency Lists

### GSM900 (including EGSM900)

CH	TX	RX	VCO TX	VCO RX	CH	TX	RX	VCO TX	VCO RX	CH	TX	RX	VCO TX	VCO RX
975	880.2	925.2	3520.8	3700.8	1	890.2	935.2	3560.8	3740.8	63	902.6	947.6	3610.4	3790.4
976	880.4	925.4	3521.6	3701.6	2	890.4	935.4	3561.6	3741.6	64	902.8	947.8	3611.2	3791.2
977	880.6	925.6	3522.4	3702.4	3	890.6	935.6	3562.4	3742.4	65	903.0	948.0	3612.0	3792.0
978	880.8	925.8	3523.2	3703.2	4	890.8	935.8	3563.2	3743.2	66	903.2	948.2	3612.8	3792.8
979	881.0	926.0	3524.0	3704.0	5	891.0	936.0	3564.0	3744.0	67	903.4	948.4	3613.6	3793.6
980	881.2	926.2	3524.8	3704.8	6	891.2	936.2	3564.8	3744.8	68	903.6	948.6	3614.4	3794.4
981	881.4	926.4	3525.6	3705.6	7	891.4	936.4	3565.6	3745.6	69	903.8	948.8	3615.2	3795.2
982	881.6	926.6	3526.4	3706.4	8	891.6	936.6	3566.4	3746.4	70	904.0	949.0	3616.0	3796.0
983	881.8	926.8	3527.2	3707.2	9	891.8	936.8	3567.2	3747.2	71	904.2	949.2	3616.8	3796.8
984	882.0	927.0	3528.0	3708.0	10	892.0	937.0	3568.0	3748.0	72	904.4	949.4	3617.6	3797.6
985	882.2	927.2	3528.8	3708.8	11	892.2	937.2	3568.8	3748.8	73	904.6	949.6	3618.4	3798.4
986	882.4	927.4	3529.6	3709.6	12	892.4	937.4	3569.6	3749.6	74	904.8	949.8	3619.2	3799.2
987	882.6	927.6	3530.4	3710.4	13	892.6	937.6	3570.4	3750.4	75	905.0	950.0	3620.0	3800.0
988	882.8	927.8	3531.2	3711.2	14	892.8	937.8	3571.2	3751.2	76	905.2	950.2	3620.8	3800.8
989	883.0	928.0	3532.0	3712.0	15	893.0	938.0	3572.0	3752.0	77	905.4	950.4	3621.6	3801.6
990	883.2	928.2	3532.8	3712.8	16	893.2	938.2	3572.8	3752.8	78	905.6	950.6	3622.4	3802.4
991	883.4	928.4	3533.6	3713.6	17	893.4	938.4	3573.6	3753.6	79	905.8	950.8	3623.2	3803.2
992	883.6	928.6	3534.4	3714.4	18	893.6	938.6	3574.4	3754.4	80	906.0	951.0	3624.0	3804.0
993	883.8	928.8	3535.2	3715.2	19	893.8	938.8	3575.2	3755.2	81	906.2	951.2	3624.8	3804.8
994	884.0	929.0	3536.0	3716.0	20	894.0	939.0	3576.0	3756.0	82	906.4	951.4	3625.6	3805.6
995	884.2	929.2	3536.8	3716.8	21	894.2	939.2	3576.8	3756.8	83	906.6	951.6	3626.4	3806.4
996	884.4	929.4	3537.6	3717.6	22	894.4	939.4	3577.6	3757.6	84	906.8	951.8	3627.2	3807.2
997	884.6	929.6	3538.4	3718.4	23	894.6	939.6	3578.4	3758.4	85	907.0	952.0	3628.0	3808.0
998	884.8	929.8	3539.2	3719.2	24	894.8	939.8	3579.2	3759.2	86	907.2	952.2	3628.8	3808.8
999	885.0	930.0	3540.0	3720.0	25	895.0	940.0	3580.0	3760.0	87	907.4	952.4	3629.6	3809.6
1000	885.2	930.2	3540.8	3720.8	26	895.2	940.2	3580.8	3760.8	88	907.6	952.6	3630.4	3810.4
1001	885.4	930.4	3541.6	3721.6	27	895.4	940.4	3581.6	3761.6	89	907.8	952.8	3631.2	3811.2
1002	885.6	930.6	3542.4	3722.4	28	895.6	940.6	3582.4	3762.4	90	908.0	953.0	3632.0	3812.0
1003	885.8	930.8	3543.2	3723.2	29	895.8	940.8	3583.2	3763.2	91	908.2	953.2	3632.8	3812.8
1004	886.0	931.0	3544.0	3724.0	30	896.0	941.0	3584.0	3764.0	92	908.4	953.4	3633.6	3813.6
1005	886.2	931.2	3544.8	3724.8	31	896.2	941.2	3584.8	3764.8	93	908.6	953.6	3634.4	3814.4
1006	886.4	931.4	3545.6	3725.6	32	896.4	941.4	3585.6	3765.6	94	908.8	953.8	3635.2	3815.2
1007	886.6	931.6	3546.4	3726.4	33	896.6	941.6	3586.4	3766.4	95	909.0	954.0	3636.0	3816.0
1008	886.8	931.8	3547.2	3727.2	34	896.8	941.8	3587.2	3767.2	96	909.2	954.2	3636.8	3816.8
1009	887.0	932.0	3548.0	3728.0	35	897.0	942.0	3588.0	3768.0	97	909.4	954.4	3637.6	3817.6
1010	887.2	932.2	3548.8	3728.8	36	897.2	942.2	3588.8	3768.8	98	909.6	954.6	3638.4	3818.4
1011	887.4	932.4	3549.6	3729.6	37	897.4	942.4	3589.6	3769.6	99	909.8	954.8	3639.2	3819.2
1012	887.6	932.6	3550.4	3730.4	38	897.6	942.6	3590.4	3770.4	100	910.0	955.0	3640.0	3820.0
1013	887.8	932.8	3551.2	3731.2	39	897.8	942.8	3591.2	3771.2	101	910.2	955.2	3640.8	3820.8
1014	888.0	933.0	3552.0	3732.0	40	898.0	943.0	3592.0	3772.0	102	910.4	955.4	3641.6	3821.6
1015	888.2	933.2	3552.8	3732.8	41	898.2	943.2	3592.8	3772.8	103	910.6	955.6	3642.4	3822.4
1016	888.4	933.4	3553.6	3733.6	42	898.4	943.4	3593.6	3773.6	104	910.8	955.8	3643.2	3823.2
1017	888.6	933.6	3554.4	3734.4	43	898.6	943.6	3594.4	3774.4	105	911.0	956.0	3644.0	3824.0
1018	888.8	933.8	3555.2	3735.2	44	898.8	943.8	3595.2	3775.2	106	911.2	956.2	3644.8	3824.8
1019	889.0	934.0	3556.0	3736.0	45	899.0	944.0	3596.0	3776.0	107	911.4	956.4	3645.6	3825.6
1020	889.2	934.2	3556.8	3736.8	46	899.2	944.2	3596.8	3776.8	108	911.6	956.6	3646.4	3826.4
1021	889.4	934.4	3557.6	3737.6	47	899.4	944.4	3597.6	3777.6	109	911.8	956.8	3647.2	3827.2
1022	889.6	934.6	3558.4	3738.4	48	899.6	944.6	3598.4	3778.4	110	912.0	957.0	3648.0	3828.0
1023	889.8	934.8	3559.2	3739.2	49	899.8	944.8	3599.2	3779.2	111	912.2	957.2	3648.8	3828.8
0	890.0	935.0	3560.0	3740.0	50	900.0	945.0	3600.0	3780.0	112	912.4	957.4	3649.6	3829.6
					51	900.2	945.2	3600.8	3780.8	113	912.6	957.6	3650.4	3830.4
					52	900.4	945.4	3601.6	3781.6	114	912.8	957.8	3651.2	3831.2
					53	900.6	945.6	3602.4	3782.4	115	913.0	958.0	3652.0	3832.0
					54	900.8	945.8	3603.2	3783.2	116	913.2	958.2	3652.8	3832.8
					55	901.0	946.0	3604.0	3784.0	117	913.4	958.4	3653.6	3833.6
					56	901.2	946.2	3604.8	3784.8	118	913.6	958.6	3654.4	3834.4
					57	901.4	946.4	3605.6	3785.6	119	913.8	958.8	3655.2	3835.2
					58	901.6	946.6	3606.4	3786.4	120	914.0	959.0	3656.0	3836.0
					59	901.8	946.8	3607.2	3787.2	121	914.2	959.2	3656.8	3836.8
					60	902.0	947.0	3608.0	3788.0	122	914.4	959.4	3657.6	3837.6
					61	902.2	947.2	3608.8	3788.8	123	914.6	959.6	3658.4	3838.4
					62	902.4	947.4	3609.6	3789.6	124	914.8	959.8	3659.2	3839.2

**GSM1800**

CH	TX	RX	VCO TX	VCO RX	CH	TX	RX	VCO TX	VCO RX	CH	TX	RX	VCO TX	VCO RX	CH	TX	RX	VCO TX	VCO RX
512	1710.2	1805.2	3420.4	3610.4	606	1729.0	1824.0	3458.0	3648.0	700	1747.8	1842.8	3495.6	3685.6	794	1766.6	1861.6	3533.2	3723.2
513	1710.4	1805.4	3420.8	3610.8	607	1729.2	1824.2	3458.4	3648.4	701	1748.0	1843.0	3496.0	3686.0	795	1766.8	1861.8	3533.6	3723.6
514	1710.6	1805.6	3421.2	3611.2	608	1729.4	1824.4	3458.8	3648.8	702	1748.2	1843.2	3496.4	3686.4	796	1767.0	1862.0	3534.0	3724.0
515	1710.8	1805.8	3421.6	3611.6	609	1729.6	1824.6	3459.2	3649.2	703	1748.4	1843.4	3496.8	3686.8	797	1767.2	1862.2	3534.4	3724.4
516	1711.0	1806.0	3422.0	3612.0	610	1729.8	1824.8	3459.6	3649.6	704	1748.6	1843.6	3497.2	3687.2	798	1767.4	1862.4	3534.8	3724.8
517	1711.2	1806.2	3422.4	3612.4	611	1730.0	1825.0	3460.0	3650.0	705	1748.8	1843.8	3497.6	3687.6	799	1767.6	1862.6	3535.2	3725.2
518	1711.4	1806.4	3422.8	3612.8	612	1730.2	1825.2	3460.4	3650.4	706	1749.0	1844.0	3498.0	3688.0	800	1767.8	1862.8	3535.6	3725.6
519	1711.6	1806.6	3423.2	3613.2	613	1730.4	1825.4	3460.8	3650.8	707	1749.2	1844.2	3498.4	3688.4	801	1768.0	1863.0	3536.0	3726.0
520	1711.8	1806.8	3423.6	3613.6	614	1730.6	1825.6	3461.2	3651.2	708	1749.4	1844.4	3498.8	3688.8	802	1768.2	1863.2	3536.4	3726.4
521	1712.0	1807.0	3424.0	3614.0	615	1730.8	1825.8	3461.6	3651.6	709	1749.6	1844.6	3499.2	3689.2	803	1768.4	1863.4	3536.8	3726.8
522	1712.2	1807.2	3424.4	3614.4	616	1731.0	1826.0	3462.0	3652.0	710	1749.8	1844.8	3499.6	3689.6	804	1768.6	1863.6	3537.2	3727.2
523	1712.4	1807.4	3424.8	3614.8	617	1731.2	1826.2	3462.4	3652.4	711	1750.0	1845.0	3500.0	3690.0	805	1768.8	1863.8	3537.6	3727.6
524	1712.6	1807.6	3425.2	3615.2	618	1731.4	1826.4	3462.8	3652.8	712	1750.2	1845.2	3500.4	3690.4	806	1769.0	1864.0	3538.0	3728.0
525	1712.8	1807.8	3425.6	3615.6	619	1731.6	1826.6	3463.2	3653.2	713	1750.4	1845.4	3500.8	3690.8	807	1769.2	1864.2	3538.4	3728.4
526	1713.0	1808.0	3426.0	3616.0	620	1731.8	1826.8	3463.6	3653.6	714	1750.6	1845.6	3501.2	3691.2	808	1769.4	1864.4	3538.8	3728.8
527	1713.2	1808.2	3426.4	3616.4	621	1732.0	1827.0	3464.0	3654.0	715	1750.8	1845.8	3501.6	3691.6	809	1769.6	1864.6	3539.2	3729.2
528	1713.4	1808.4	3426.8	3616.8	622	1732.2	1827.2	3464.4	3654.4	716	1751.0	1846.0	3502.0	3692.0	810	1769.8	1864.8	3539.6	3729.6
529	1713.6	1808.6	3427.2	3617.2	623	1732.4	1827.4	3464.8	3654.8	717	1751.2	1846.2	3502.4	3692.4	811	1770.0	1865.0	3540.0	3730.0
530	1713.8	1808.8	3427.6	3617.6	624	1732.6	1827.6	3465.2	3655.2	718	1751.4	1846.4	3502.8	3692.8	812	1770.2	1865.2	3540.4	3730.4
531	1714.0	1809.0	3428.0	3618.0	625	1732.8	1827.8	3465.6	3655.6	719	1751.6	1846.6	3503.2	3693.2	813	1770.4	1865.4	3540.8	3730.8
532	1714.2	1809.2	3428.4	3618.4	626	1733.0	1828.0	3466.0	3656.0	720	1751.8	1846.8	3503.6	3693.6	814	1770.6	1865.6	3541.2	3731.2
533	1714.4	1809.4	3428.8	3618.8	627	1733.2	1828.2	3466.4	3656.4	721	1752.0	1847.0	3504.0	3694.0	815	1770.8	1865.8	3541.6	3731.6
534	1714.6	1809.6	3429.2	3619.2	628	1733.4	1828.4	3466.8	3656.8	722	1752.2	1847.2	3504.4	3694.4	816	1771.0	1866.0	3542.0	3732.0
535	1714.8	1809.8	3429.6	3619.6	629	1733.6	1828.6	3467.2	3657.2	723	1752.4	1847.4	3504.8	3694.8	817	1771.2	1866.2	3542.4	3732.4
536	1715.0	1810.0	3430.0	3620.0	630	1733.8	1828.8	3467.6	3657.6	724	1752.6	1847.6	3505.2	3695.2	818	1771.4	1866.4	3542.8	3732.8
537	1715.2	1810.2	3430.4	3620.4	631	1734.0	1829.0	3468.0	3658.0	725	1752.8	1847.8	3505.6	3695.6	819	1771.6	1866.6	3543.2	3733.2
538	1715.4	1810.4	3430.8	3620.8	632	1734.2	1829.2	3468.4	3658.4	726	1753.0	1848.0	3506.0	3696.0	820	1771.8	1866.8	3543.6	3733.6
539	1715.6	1810.6	3431.2	3621.2	633	1734.4	1829.4	3468.8	3658.8	727	1753.2	1848.2	3506.4	3696.4	821	1772.0	1867.0	3544.0	3734.0
540	1715.8	1810.8	3431.6	3621.6	634	1734.6	1829.6	3469.2	3659.2	728	1753.4	1848.4	3506.8	3696.8	822	1772.2	1867.2	3544.4	3734.4
541	1716.0	1811.0	3432.0	3622.0	635	1734.8	1829.8	3469.6	3659.6	729	1753.6	1848.6	3507.2	3697.2	823	1772.4	1867.4	3544.8	3734.8
542	1716.2	1811.2	3432.4	3622.4	636	1735.0	1830.0	3470.0	3660.0	730	1753.8	1848.8	3507.6	3697.6	824	1772.6	1867.6	3545.2	3735.2
543	1716.4	1811.4	3432.8	3622.8	637	1735.2	1830.2	3470.4	3660.4	731	1754.0	1849.0	3508.0	3698.0	825	1772.8	1867.8	3545.6	3735.6
544	1716.6	1811.6	3433.2	3623.2	638	1735.4	1830.4	3470.8	3660.8	732	1754.2	1849.2	3508.4	3698.4	826	1773.0	1868.0	3546.0	3736.0
545	1716.8	1811.8	3433.6	3623.6	639	1735.6	1830.6	3471.2	3661.2	733	1754.4	1849.4	3508.8	3698.8	827	1773.2	1868.2	3546.4	3736.4
546	1717.0	1812.0	3434.0	3624.0	640	1735.8	1830.8	3471.6	3661.6	734	1754.6	1849.6	3509.2	3699.2	828	1773.4	1868.4	3546.8	3736.8
547	1717.2	1812.2	3434.4	3624.4	641	1736.0	1831.0	3472.0	3662.0	735	1754.8	1849.8	3509.6	3699.6	829	1773.6	1868.6	3547.2	3737.2
548	1717.4	1812.4	3434.8	3624.8	642	1736.2	1831.2	3472.4	3662.4	736	1755.0	1850.0	3510.0	3700.0	830	1773.8	1868.8	3547.6	3737.6
549	1717.6	1812.6	3435.2	3625.2	643	1736.4	1831.4	3472.8	3662.8	737	1755.2	1850.2	3510.4	3700.4	831	1774.0	1869.0	3548.0	3738.0
550	1717.8	1812.8	3435.6	3625.6	644	1736.6	1831.6	3473.2	3663.2	738	1755.4	1850.4	3510.8	3700.8	832	1774.2	1869.2	3548.4	3738.4
551	1718.0	1813.0	3436.0	3626.0	645	1736.8	1831.8	3473.6	3663.6	739	1755.6	1850.6	3511.2	3701.2	833	1774.4	1869.4	3548.8	3738.8
552	1718.2	1813.2	3436.4	3626.4	646	1737.0	1832.0	3474.0	3664.0	740	1755.8	1850.8	3511.6	3701.6	834	1774.6	1869.6	3549.2	3739.2
553	1718.4	1813.4	3436.8	3626.8	647	1737.2	1832.2	3474.4	3664.4	741	1756.0	1851.0	3512.0	3702.0	835	1774.8	1869.8	3549.6	3739.6
554	1718.6	1813.6	3437.2	3627.2	648	1737.4	1832.4	3474.8	3664.8	742	1756.2	1851.2	3512.4	3702.4	836	1775.0	1870.0	3550.0	3740.0
555	1718.8	1813.8	3437.6	3627.6	649	1737.6	1832.6	3475.2	3665.2	743	1756.4	1851.4	3512.8	3702.8	837	1775.2	1870.2	3550.4	3740.4
556	1719.0	1814.0	3438.0	3628.0	650	1737.8	1832.8	3475.6	3665.6	744	1756.6	1851.6	3513.2	3703.2	838	1775.4	1870.4	3550.8	3740.8
557	1719.2	1814.2	3438.4	3628.4	651	1738.0	1833.0	3476.0	3666.0	745	1756.8	1851.8	3513.6	3703.6	839	1775.6	1870.6	3551.2	3741.2
558	1719.4	1814.4	3438.8	3628.8	652	1738.2	1833.2	3476.4	3666.4	746	1757.0	1852.0	3514.0	3704.0	840	1775.8	1870.8	3551.6	3741.6
559	1719.6	1814.6	3439.2	3629.2	653	1738.4	1833.4	3476.8	3666.8	747	1757.2	1852.2	3514.4	3704.4	841	1776.0	1871.0	3552.0	3742.0
560	1719.8	1814.8	3439.6	3629.6	654	1738.6	1833.6	3477.2	3667.2	748	1757.4	1852.4	3514.8	3704.8	842	1776.2	1871.2	3552.4	3742.4
561	1720.0	1815.0	3440.0	3630.0	655	1738.8	1833.8	3477.6	3667.6	749	1757.6	1852.6	3515.2	3705.2	843	1776.4	1871.4	3552.8	3742.8
562	1720.2	1815.2	3440.4	3630.4	656	1739.0	1834.0	3478.0	3668.0	750	1757.8	1852.8	3515.6	3705.6	844	1776.6	1871.6	3553.2	3743.2
563	1720.4	1815.4	3440.8	3630.8	657	1739.2	1834.2	3478.4	3668.4	751	1758.0	1853.0	3516.0	3706.0	845	1776.8	1871.8	3553.6	3743.6
564	1720.6	1815.6	3441.2	3631.2	658	1739.4	1834.4	3478.8	3668.8	752	1758.2	1853.2	3516.4	3706.4	846	1777.0	1872.0	3554.0	3744.0
565	1720.8	1815.8	3441.6	3631.6	659	1739.6	1834.6	3479.2	3669.2	753	1758.4	1853.4	3516.8	3706.8	847	1777.2	1872.2	3554.4	3744.4
566	1721.0	1816.0	3442.0	3632.0	660	1739.8	1834.8	3479.6	3669.6	754	1758.6	1853.6	3517.2	3707.2	848	1777.4	1872.4	3554.8	3744.8
567	1721.2	1816.2	3442.4	3632.4	661	1740.0	1835.0	3480.0	3670.0	755	1758.8	1853.8	3517.6	3707.6	849	1777.6	1872.6	3555.2	3745.2
568	1721.4	1816.4	3442.8	3632.8	662														



**GSM1900**

CH	TX	RX	VCO TX	VCO RX	CH	TX	RX	VCO TX	VCO RX	CH	TX	RX	VCO TX	VCO RX	CH	TX	RX	VCO TX	VCO RX
512	1850.2	1930.2	3700.4	3860.4	606	1869.0	1949.0	3738.0	3898.0	700	1887.8	1967.8	3775.6	3935.6	794	1906.6	1986.6	3813.2	3973.2
513	1850.4	1930.4	3700.8	3860.8	607	1869.2	1949.2	3738.4	3898.4	701	1888.0	1968.0	3776.0	3936.0	795	1906.8	1986.8	3813.6	3973.6
514	1850.6	1930.6	3701.2	3861.2	608	1869.4	1949.4	3738.8	3898.8	702	1888.2	1968.2	3776.4	3936.4	796	1907.0	1987.0	3814.0	3974.0
515	1850.8	1930.8	3701.6	3861.6	609	1869.6	1949.6	3739.2	3899.2	703	1888.4	1968.4	3776.8	3936.8	797	1907.2	1987.2	3814.4	3974.4
516	1851.0	1931.0	3702.0	3862.0	610	1869.8	1949.8	3739.6	3899.6	704	1888.6	1968.6	3777.2	3937.2	798	1907.4	1987.4	3814.8	3974.8
517	1851.2	1931.2	3702.4	3862.4	611	1870.0	1950.0	3740.0	3900.0	705	1888.8	1968.8	3777.6	3937.6	799	1907.6	1987.6	3815.2	3975.2
518	1851.4	1931.4	3702.8	3862.8	612	1870.2	1950.2	3740.4	3900.4	706	1889.0	1969.0	3778.0	3938.0	800	1907.8	1987.8	3815.6	3975.6
519	1851.6	1931.6	3703.2	3863.2	613	1870.4	1950.4	3740.8	3900.8	707	1889.2	1969.2	3778.4	3938.4	801	1908.0	1988.0	3816.0	3976.0
520	1851.8	1931.8	3703.6	3863.6	614	1870.6	1950.6	3741.2	3901.2	708	1889.4	1969.4	3778.8	3938.8	802	1908.2	1988.2	3816.4	3976.4
521	1852.0	1932.0	3704.0	3864.0	615	1870.8	1950.8	3741.6	3901.6	709	1889.6	1969.6	3779.2	3939.2	803	1908.4	1988.4	3816.8	3976.8
522	1852.2	1932.2	3704.4	3864.4	616	1871.0	1951.0	3742.0	3902.0	710	1889.8	1969.8	3779.6	3939.6	804	1908.6	1988.6	3817.2	3977.2
523	1852.4	1932.4	3704.8	3864.8	617	1871.2	1951.2	3742.4	3902.4	711	1890.0	1970.0	3780.0	3940.0	805	1908.8	1988.8	3817.6	3977.6
524	1852.6	1932.6	3705.2	3865.2	618	1871.4	1951.4	3742.8	3902.8	712	1890.2	1970.2	3780.4	3940.4	806	1909.0	1989.0	3818.0	3978.0
525	1852.8	1932.8	3705.6	3865.6	619	1871.6	1951.6	3743.2	3903.2	713	1890.4	1970.4	3780.8	3940.8	807	1909.2	1989.2	3818.4	3978.4
526	1853.0	1933.0	3706.0	3866.0	620	1871.8	1951.8	3743.6	3903.6	714	1890.6	1970.6	3781.2	3941.2	808	1909.4	1989.4	3818.8	3978.8
527	1853.2	1933.2	3706.4	3866.4	621	1872.0	1952.0	3744.0	3904.0	715	1890.8	1970.8	3781.6	3941.6	809	1909.6	1989.6	3819.2	3979.2
528	1853.4	1933.4	3706.8	3866.8	622	1872.2	1952.2	3744.4	3904.4	716	1891.0	1971.0	3782.0	3942.0	810	1909.8	1989.8	3819.6	3979.6
529	1853.6	1933.6	3707.2	3867.2	623	1872.4	1952.4	3744.8	3904.8	717	1891.2	1971.2	3782.4	3942.4					
530	1853.8	1933.8	3707.6	3867.6	624	1872.6	1952.6	3745.2	3905.2	718	1891.4	1971.4	3782.8	3942.8					
531	1854.0	1934.0	3708.0	3868.0	625	1872.8	1952.8	3745.6	3905.6	719	1891.6	1971.6	3783.2	3943.2					
532	1854.2	1934.2	3708.4	3868.4	626	1873.0	1953.0	3746.0	3906.0	720	1891.8	1971.8	3783.6	3943.6					
533	1854.4	1934.4	3708.8	3868.8	627	1873.2	1953.2	3746.4	3906.4	721	1892.0	1972.0	3784.0	3944.0					
534	1854.6	1934.6	3709.2	3869.2	628	1873.4	1953.4	3746.8	3906.8	722	1892.2	1972.2	3784.4	3944.4					
535	1854.8	1934.8	3709.6	3869.6	629	1873.6	1953.6	3747.2	3907.2	723	1892.4	1972.4	3784.8	3944.8					
536	1855.0	1935.0	3710.0	3870.0	630	1873.8	1953.8	3747.6	3907.6	724	1892.6	1972.6	3785.2	3945.2					
537	1855.2	1935.2	3710.4	3870.4	631	1874.0	1954.0	3748.0	3908.0	725	1892.8	1972.8	3785.6	3945.6					
538	1855.4	1935.4	3710.8	3870.8	632	1874.2	1954.2	3748.4	3908.4	726	1893.0	1973.0	3786.0	3946.0					
539	1855.6	1935.6	3711.2	3871.2	633	1874.4	1954.4	3748.8	3908.8	727	1893.2	1973.2	3786.4	3946.4					
540	1855.8	1935.8	3711.6	3871.6	634	1874.6	1954.6	3749.2	3909.2	728	1893.4	1973.4	3786.8	3946.8					
541	1856.0	1936.0	3712.0	3872.0	635	1874.8	1954.8	3749.6	3909.6	729	1893.6	1973.6	3787.2	3947.2					
542	1856.2	1936.2	3712.4	3872.4	636	1875.0	1955.0	3750.0	3910.0	730	1893.8	1973.8	3787.6	3947.6					
543	1856.4	1936.4	3712.8	3872.8	637	1875.2	1955.2	3750.4	3910.4	731	1894.0	1974.0	3788.0	3948.0					
544	1856.6	1936.6	3713.2	3873.2	638	1875.4	1955.4	3750.8	3910.8	732	1894.2	1974.2	3788.4	3948.4					
545	1856.8	1936.8	3713.6	3873.6	639	1875.6	1955.6	3751.2	3911.2	733	1894.4	1974.4	3788.8	3948.8					
546	1857.0	1937.0	3714.0	3874.0	640	1875.8	1955.8	3751.6	3911.6	734	1894.6	1974.6	3789.2	3949.2					
547	1857.2	1937.2	3714.4	3874.4	641	1876.0	1956.0	3752.0	3912.0	735	1894.8	1974.8	3789.6	3949.6					
548	1857.4	1937.4	3714.8	3874.8	642	1876.2	1956.2	3752.4	3912.4	736	1895.0	1975.0	3790.0	3950.0					
549	1857.6	1937.6	3715.2	3875.2	643	1876.4	1956.4	3752.8	3912.8	737	1895.2	1975.2	3790.4	3950.4					
550	1857.8	1937.8	3715.6	3875.6	644	1876.6	1956.6	3753.2	3913.2	738	1895.4	1975.4	3790.8	3950.8					
551	1858.0	1938.0	3716.0	3876.0	645	1876.8	1956.8	3753.6	3913.6	739	1895.6	1975.6	3791.2	3951.2					
552	1858.2	1938.2	3716.4	3876.4	646	1877.0	1957.0	3754.0	3914.0	740	1895.8	1975.8	3791.6	3951.6					
553	1858.4	1938.4	3716.8	3876.8	647	1877.2	1957.2	3754.4	3914.4	741	1896.0	1976.0	3792.0	3952.0					
554	1858.6	1938.6	3717.2	3877.2	648	1877.4	1957.4	3754.8	3914.8	742	1896.2	1976.2	3792.4	3952.4					
555	1858.8	1938.8	3717.6	3877.6	649	1877.6	1957.6	3755.2	3915.2	743	1896.4	1976.4	3792.8	3952.8					
556	1859.0	1939.0	3718.0	3878.0	650	1877.8	1957.8	3755.6	3915.6	744	1896.6	1976.6	3793.2	3953.2					
557	1859.2	1939.2	3718.4	3878.4	651	1878.0	1958.0	3756.0	3916.0	745	1896.8	1976.8	3793.6	3953.6					
558	1859.4	1939.4	3718.8	3878.8	652	1878.2	1958.2	3756.4	3916.4	746	1897.0	1977.0	3794.0	3954.0					
559	1859.6	1939.6	3719.2	3879.2	653	1878.4	1958.4	3756.8	3916.8	747	1897.2	1977.2	3794.4	3954.4					
560	1859.8	1939.8	3719.6	3879.6	654	1878.6	1958.6	3757.2	3917.2	748	1897.4	1977.4	3794.8	3954.8					
561	1860.0	1940.0	3720.0	3880.0	655	1878.8	1958.8	3757.6	3917.6	749	1897.6	1977.6	3795.2	3955.2					
562	1860.2	1940.2	3720.4	3880.4	656	1879.0	1959.0	3758.0	3918.0	750	1897.8	1977.8	3795.6	3955.6					
563	1860.4	1940.4	3720.8	3880.8	657	1879.2	1959.2	3758.4	3918.4	751	1898.0	1978.0	3796.0	3956.0					
564	1860.6	1940.6	3721.2	3881.2	658	1879.4	1959.4	3758.8	3918.8	752	1898.2	1978.2	3796.4	3956.4					
565	1860.8	1940.8	3721.6	3881.6	659	1879.6	1959.6	3759.2	3919.2	753	1898.4	1978.4	3796.8	3956.8					
566	1861.0	1941.0	3722.0	3882.0	660	1879.8	1959.8	3759.6	3919.6	754	1898.6	1978.6	3797.2	3957.2					
567	1861.2	1941.2	3722.4	3882.4	661	1880.0	1960.0	3760.0	3920.0	755	1898.8	1978.8	3797.6	3957.6					
568	1861.4	1941.4	3722.8	3882.8	662	1880.2	1960.2	3760.4	3920.4	756	1899.0	1979.0	3798.0	3958.0					
569	1861.6	1941.6	3723.2	3883.2	663	1880.4	1960.4	3760.8	3920.8	757	1899.2	1979.2	3798.4	3958.4					
570	1861.8	1941.8	3723.6	3883.6	664	1880.6	1960.6	3761.2	3921.2	758	1899.4	1979.4	3798.8	3958.8					

**■ RF tunings after repairs**

The following tunings have to be performed after repairs:

- Repairs in the Tx part require "Tx Power Level Tuning".
- When component replacements around the modulator area (RF path from UEM via RF ASIC to RF PA) have been done, "Tx IQ Tuning" is additionally required.
- In general Rx repairs, the front-end always requires "Rx Calibration" and "Rx Band Filter Calibration" for all three bands.
- Repairs in the PLL circuit always require "Rx Calibration" of the low band.
- If the RF ASIC is replaced, all calibrations mentioned above have to be done.

Refer to Chapter 3, Service Software Instructions, for instructions on the above-mentioned tunings.